

# LCD Digital Color TV

**Setup Guide** (Operating Instructions)

Setting up your TV

To watch TV

Additional Information

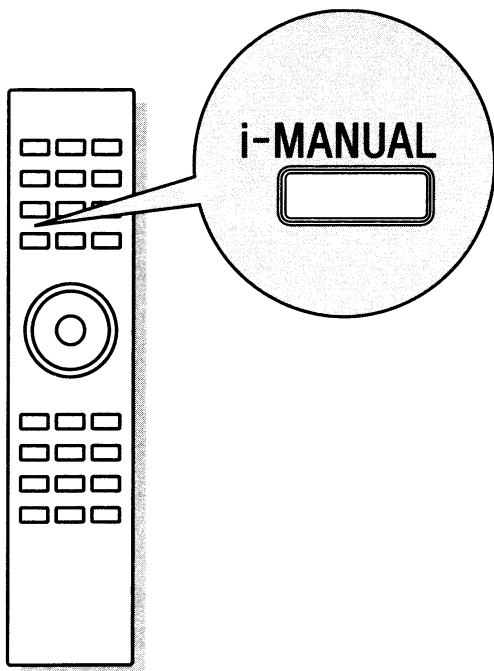

## Sony Customer Support

U.S.A.: [www.sony.com/tvsupport](http://www.sony.com/tvsupport)

Canada: [www.sony.ca/support](http://www.sony.ca/support)

United States

Canada

1.800.222.SONY

1.877.899.SONY

Please Do Not Return  
the Product to the Store

# BRAVIA

## Owner's Record

The information label are located on the rear of the TV. Record model name and serial numbers on the information label in the spaces provided below. Refer to them whenever you call upon your Sony dealer regarding this TV.

Model Name

---

Serial No.

---

## CAUTION

To prevent electric shock and blade exposure, do not use this polarized AC plug with an extension cord, receptacle or other outlet unless the blades can be fully inserted.

- Operate the TV only on 110-240 V AC (U.S.A./Canada 120 V AC)
- Avoid operating the TV at temperatures below 41°F (5°C).
- Some people may experience discomfort (such as eye strain, fatigue, or nausea) while watching 3D video images or playing 3D video games. Sony recommends that all viewers take regular breaks while watching 3D video images or playing 3D video games. The length and frequency of necessary breaks will vary from person to person. You must decide what works best. If you experience any discomfort, you should stop watching the 3D video images or playing 3D video games until the discomfort ends; consult a doctor if you believe necessary. You should also review (i) the instruction manual of any other device or media used with this television and (ii) our website ([www.sony.com/tvsupport](http://www.sony.com/tvsupport)) for the latest information. The vision of young children (especially those under six years old) is still under development. Consult your doctor (such as a pediatrician or eye doctor) before allowing young children to watch 3D video images or play 3D video games. Adults should supervise young children to ensure they follow the recommendations listed above.
- When using the simulated 3D function, please note that the displayed image is modified from the original due to the conversion done by this television.

## Licensing Information

Macintosh is a trademark of Apple Inc., registered in the U.S. and other countries.

HDMI, the HDMI Logo, and High-Definition Multimedia Interface are trademarks or registered trademarks of HDMI Licensing LLC in the United States and other countries.

Ferguson Patent Properties, LLC:  
U.S. Patent No. 5,717,422  
U.S. Patent No. 6,816,141

Manufactured under license from Dolby Laboratories. Dolby and the double-D symbol are trademarks of Dolby Laboratories.

In the United States, TV Guide and TV Guide On Screen are registered trademarks of TV Guide Entertainment Group, Inc. and/or its subsidiaries or affiliates, and are used under a license by Gemstar-TV Guide International, Inc. and/or its subsidiaries. In Canada, TV Guide is a registered mark of Transcontinental Inc., and is used under a license by Gemstar-TV Guide International, Inc. and/or its subsidiaries.

The TV Guide On Screen system is manufactured under license from Gemstar-TV Guide International, Inc. and/or its subsidiaries.

The TV Guide On Screen system is protected by one or more of the following United States patents 6,498,895; 6,850,693; 6,396,546; 5,940,073; 6,239,794 to Gemstar-TV Guide International, Inc. and/or its subsidiaries.

Gemstar-TV Guide International, Inc. and/or its related affiliates are not in any way liable for the accuracy or availability of the program schedule information or other data in the TV Guide On Screen system and cannot guarantee service availability in your area. In no event shall Gemstar-TV Guide International, Inc. and/or its related affiliates be liable for any damages in connection with the accuracy or availability of the program schedule information or other data in the TV Guide On Screen system.

Blu-ray Disc is a trademark.

“BRAVIA” and BRAVIA, S-Force, Motionflow, BRAVIA Sync, and  are trademarks or registered marks of Sony Corporation.

“XMB™” and “xross media bar” are trademarks of Sony Corporation and Sony Computer Entertainment Inc.

“PlayStation” is a registered trademark and “PS3” is a trademark of Sony Computer Entertainment Inc.

DLNA®, the DLNA Logo and DLNA CERTIFIED® are trademarks, service marks, or certification marks of the Digital Living Network Alliance.



Your BRAVIA TV is ENERGY STAR® qualified in the “Home” mode.

It meets strict energy efficiency guidelines set by the U.S. Environmental Protection Agency and Department of Energy. ENERGY STAR is a joint program of these government agencies, designed to promote energy efficient products and practices.

Changes to certain features, settings, and functionalities of this TV (i.e. TV Guide, Picture/Sound, Light Sensor, Power Savings) can increase or change the power consumption.

Depending upon such changed settings, the power consumption may exceed the limits required for the ENERGY STAR qualification in the “Home” mode.

The 55 class has a 54.6 inch viewable image size (measured diagonally).



- The illustrations of the remote control used in this manual are of the RM-YD040 unless otherwise stated.
- The illustrations used in this manual may differ depending on your TV model.



# Table of Contents

Checking the accessories.....	4
Inserting batteries into the remote control .....	4

## Setting up your TV

Attaching the Table-Top Stand.....	6
Connecting the TV .....	8
Securing the TV.....	12
Organizing the AC power cord .....	13
Running initial setup .....	14
Detaching the Table-Top Stand from the TV.....	14
Using a Wall-Mount Bracket.....	15
Installing the TV Against a Wall or Enclosed Area .....	15

## To watch TV

To watch programs.....	16
To use the TV features.....	16
To use i-Manual.....	17

## Additional Information

Troubleshooting.....	18
Specifications .....	20

- Operating instructions are built into your **BRAVIA** TV. Refer to “To use i-Manual” for operation (page 17).
- Retain this manual for future reference.

### The BRAVIA® Full HDTV Experience

Thank you for choosing Sony! Your new BRAVIA® TV opens the door to the “Full HDTV Experience.” This document will help you get the most out of your TV.

Please take a moment to register your TV at:

**U.S.A.:** <http://productregistration.sony.com>

**Canada:** <http://www.SonyStyle.ca/registration>

#### Four Steps to a Full HD Experience

Set, Source, Sound, and Setup.

#### 1 Set

Now that you have made the best selection in LCD TV technology, be sure to remove all accessory contents from the packaging before setting up your TV.

#### 2 Source

To experience the stunning detail of your **BRAVIA** TV, you need access to HD programming.

- Upgrade your signal or content source to high-definition (HD) by contacting your HD service provider.

- Receive over-the-air HD broadcasts with an HD-quality antenna connected directly to the back of your TV.

Visit [www.antennaweb.org](http://www.antennaweb.org) for more information on antenna selection and setup.

- Discover the wealth of entertainment now available on super-high resolution Blu-ray Disc™ player and other Sony HD equipment.

#### 3 Sound

Complete the high-definition experience with a **BRAVIA** Sync™ surround sound system or A/V receiver from Sony.

#### 4 Setup

Install your TV and connect your sources. See page 8 for sample connection diagrams.

To help assure the highest quality for your HD experience, use Sony HDMI (High-Definition Multimedia Interface) cables.

**To learn more about HDTV, visit:**

**U.S.A.:** <http://www.sony.com/HDTV>

**Canada:** <http://www.SonyStyle.ca/hd>

This TV displays all video input signals in a resolution of 1,920 dots × 1,080 lines.

---

## Checking the accessories

AC power cord (1)

Remote control (1)\*<sup>1</sup>

Size AAA batteries (2)

Table-Top Stand (1)\*<sup>2</sup>

Fixing screws for Table-Top Stand  
(M5 × 16) (4)

Assembling screws for Table-Top Stand  
(M5 × 16) (4) (KDL-40HX800 only)

Stand rear cover (1)\*<sup>3</sup>

\*1 Please refer to the model name printed on the remote control.

\*2 KDL-40HX800 requires assembling.  
Refer to other leaflet to assemble the Table-Top Stand.

\*3 For KDL-55/46HX800, the stand rear cover is factory-attached to the Table-Top Stand.

---

## Inserting batteries into the remote control

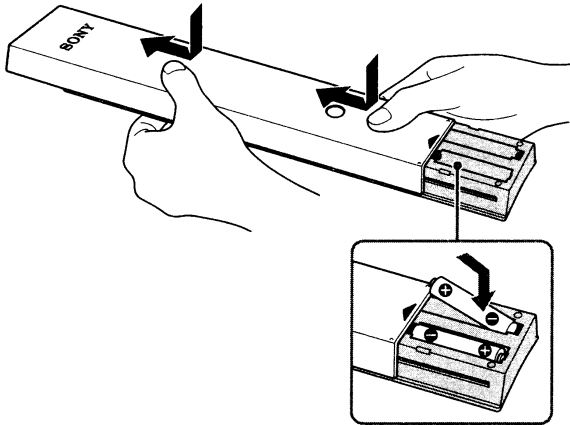

- 1 Remove the protection sheet.
- 2 Push and slide the cover upward.

## Guidelines for Remote Control

- Point your remote control directly at the IR sensor located on your TV.
- Make sure that no objects are blocking the path between the remote control and the IR sensor on your TV.
- Fluorescent lamps can interfere with your remote control; try turning off the fluorescent lamps.
- If you are having problems with the remote control, reinsert or replace your batteries and make sure that they are correctly inserted.

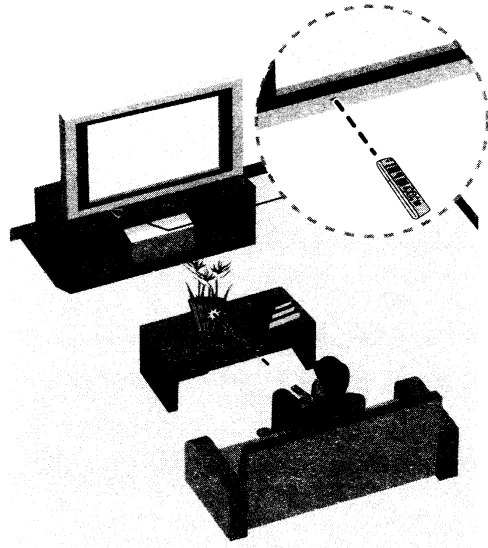

## Programming the Remote Control (For RM-ED038 and RM-ED053 remote control users)

Your remote control can be programmed to use other equipment and is pre-programmed to operate the following Sony equipment.

Function Button	Sony Equipment	Code Number
DVD	DVD Player	31033
AMP	Receiver	52172
STB	Digital Satellite	01639

### Programming Other Equipment

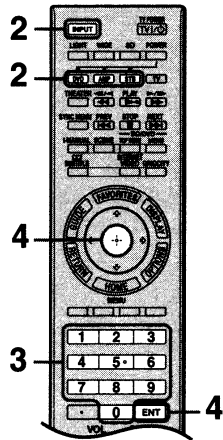

- Button names may differ slightly depending on the remote control.

Follow the steps below to program your TV remote control.

- 1 Look for the code in the Manufacturer's Code List (refer to i-Manual) that corresponds to the equipment you would like to operate with the Sony remote control. If more than one code is provided, try programming the first code listed. If your equipment's code is not listed, visit <http://esupport.sony.com/remotecodes> for a more comprehensive list.
- 2 Press and hold a **DVD**, **AMP** or **STB** function button simultaneously with **INPUT** button and release.  
When in the programming mode, the function button (**DVD**, **AMP**, **STB**) blinks for approximately 30 seconds until a code is entered.
- 3 Enter the five digit code using **0** - **9** while the function buttons (**DVD**, **AMP**, **STB**) are lit. If the code is not entered within 30 seconds, you must repeat step 2.
- 4 Press **(+)** or **ENT** to confirm the code. If successfully programmed, the function button (**DVD**, **AMP**, **STB**) will blink twice, if not, it blinks five times.

### Confirm the Programming

If you can turn your equipment on and off using the green **POWER** button, the programming is complete. If not, try the next code listed.



- In some cases, you may not be able to program your remote control. If this is the case, use your equipment's own remote control.
- Any of the function buttons (**DVD**, **AMP**, **STB**) can be programmed to operate other equipment regardless of the labeling. For example, if programmed with the correct code, a Blu-ray Disc player can be operated with the **DVD** button. This is useful if your equipment does not match any of the labeled buttons.

### To reset the remote control to the factory default:

Press **SCENE**, **TV POWER**, and **(+)** simultaneously. The four function buttons (**DVD**, **AMP**, **STB**, and **TV**) blink when successfully reset.

# Setting up your TV

Some TV models are packaged with a detached Table-Top Stand so you can mount your TV to a wall right away. If you are not mounting the TV to a wall, you will need to attach the Table-Top Stand. You will need a Phillips screwdriver and the supplied screws to complete the task. Look for the supplied Table-Top Stand instruction leaflet.

Be sure to consider the following while setting up your TV:

- Disconnect all cables when carrying the TV.
- Carry the TV with the adequate number of people; larger size TVs require two or more people.
- Correct hand placement while carrying the TV is very important for safety and to avoid damage.

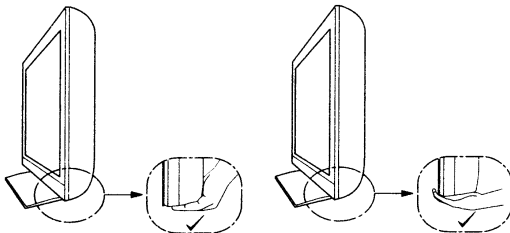
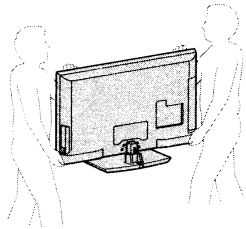

For XBR-52/46HX909 For KDL-55/46/40HX800

- Ensure your TV has adequate ventilation, see page 15.
- For best picture quality, do not expose the screen to direct illumination or sunlight.
- Avoid installing the TV in a room with reflective wall and floor materials.
- Avoid moving the TV from a cold area to a warm area. Sudden room temperature changes may cause moisture condensation. This may cause the TV to show poor picture and/or poor color. Should this occur, allow moisture to evaporate completely before powering the TV on.

## Attaching the Table-Top Stand

Refer to the supplied Table-Top Stand instruction leaflet for proper attachment for some TV models.

- 1** Gently slide the TV unit onto the Table-Top Stand and align the screw holes.



- Do not put stress on the LCD panel or the frame around the screen.
- Be careful to not pinch your hands or the AC power cord when you install the TV unit to the Table-Top Stand.

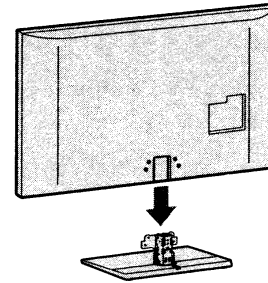

- 2** Use the supplied screws to attach the TV unit to the Table-Top Stand.

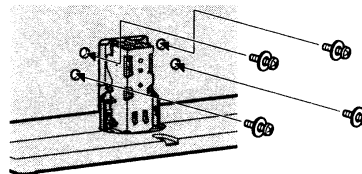

- If you use an electric screwdriver, set the tightening torque at approximately 1.5 N·m {15 kgf·cm}.
- 3** For XBR-52/46HX909 and KDL-40HX800, after all the screws are tighten cover the Table-Top Stand with the supplied stand rear cover.



- You can attach the TV to the Table-Top Stand with the stand rear cover on with the exception of XBR-52/46HX909 and KDL-40HX800. XBR-52/46HX909 and KDL-40HX800 must follow the above instructions.

## Adjusting the viewing angle (XBR-52/46HX909 only)



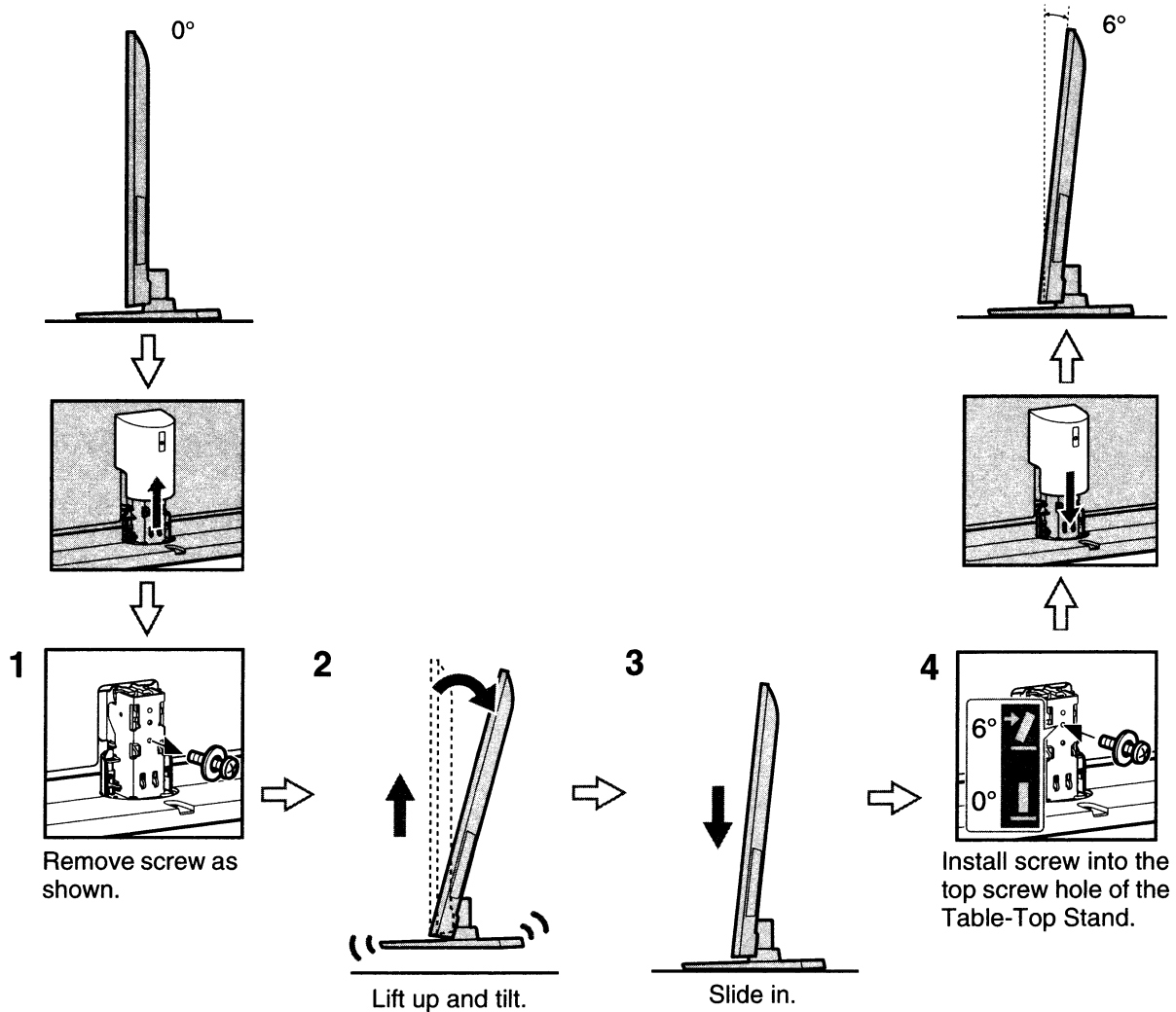

This TV can be adjusted within the angles shown below.

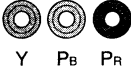

- Reverse the steps when readjusting the angle back to 0 degrees.

## Connecting the TV

The following chart shows the high-definition (HD) and standard-definition (SD) video formats supported by your **BRAVIA** TV inputs.

	INPUT	VIDEO	AUDIO	SUPPORTED FORMATS							
				1080/24p	1080p	1080i	720/24p	720p	480p	480i	PC*
HD	HDMI		When HDMI is connected to DVI with an adapter, a separate Audio L/R is necessary.	✓	✓	✓	✓	✓	✓	✓	✓
	COMPONENT	 Y Pb Pr	 Audio L/R		✓	✓		✓	✓	✓	
SD	VIDEO	 Composite video connection	 Audio L/R							✓	

\* For supported PC formats refer to the i-Manual.

### Recommendation of the F type plug

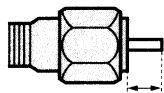

1.5 mm

Projection of the inner wire from the connection part must be less than 1.5 mm.

**Shown with a Set Top Box with HDMI connection**

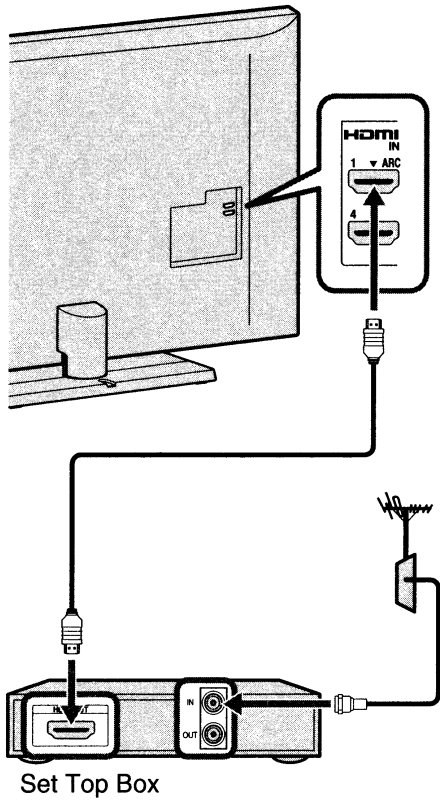

**Shown with a Set Top Box with COMPONENT connection**

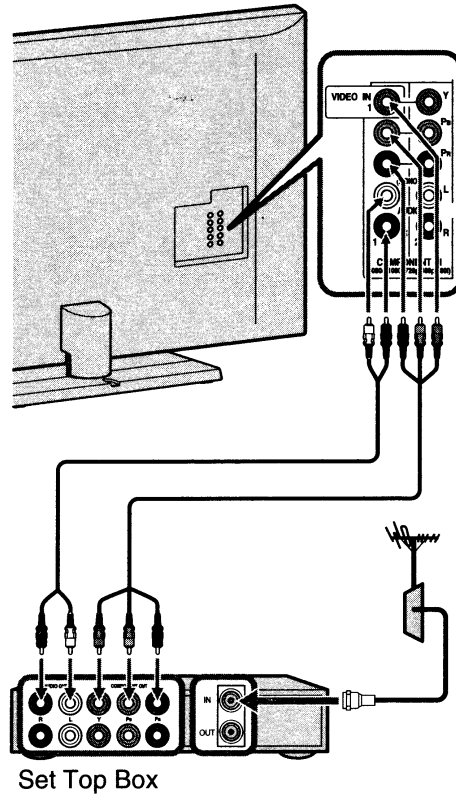

**Cable System or VHF/UHF Antenna System**

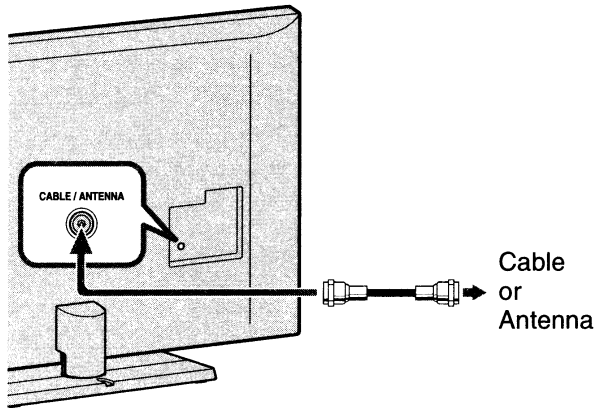

**Shown with HD BRAVIA® Sync™ Basic Connection**

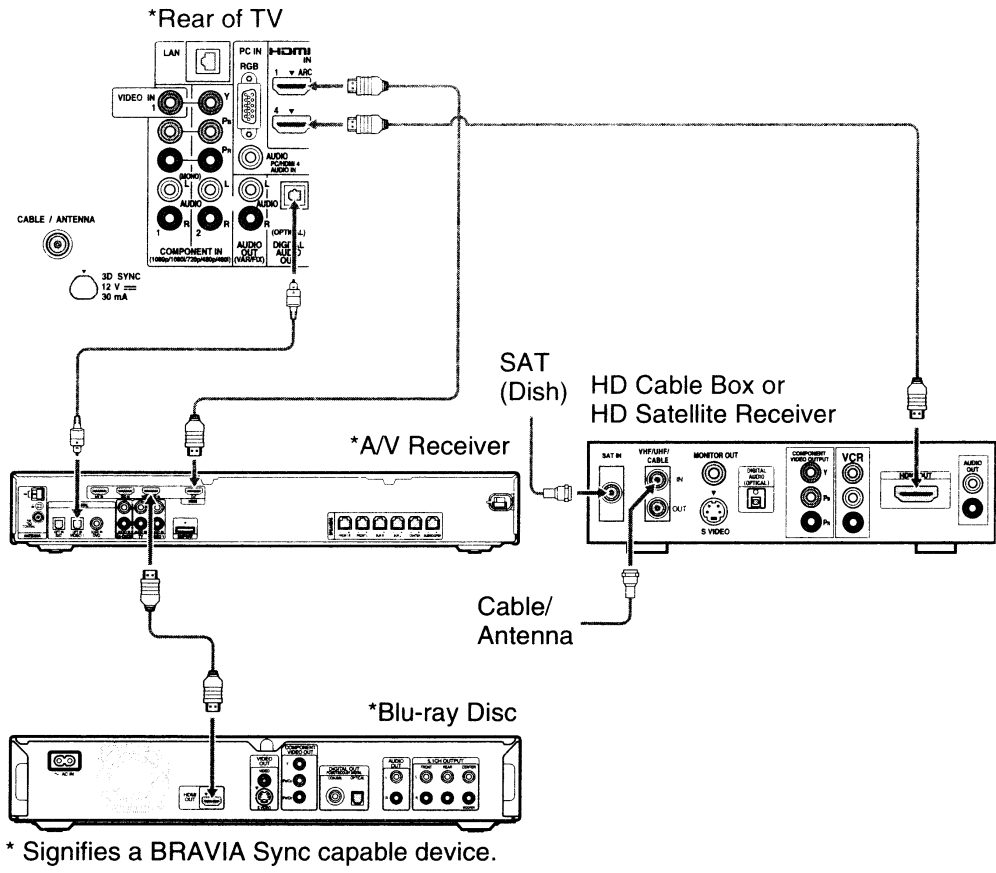

**Shown with HD Basic Connection with Home Theater System**

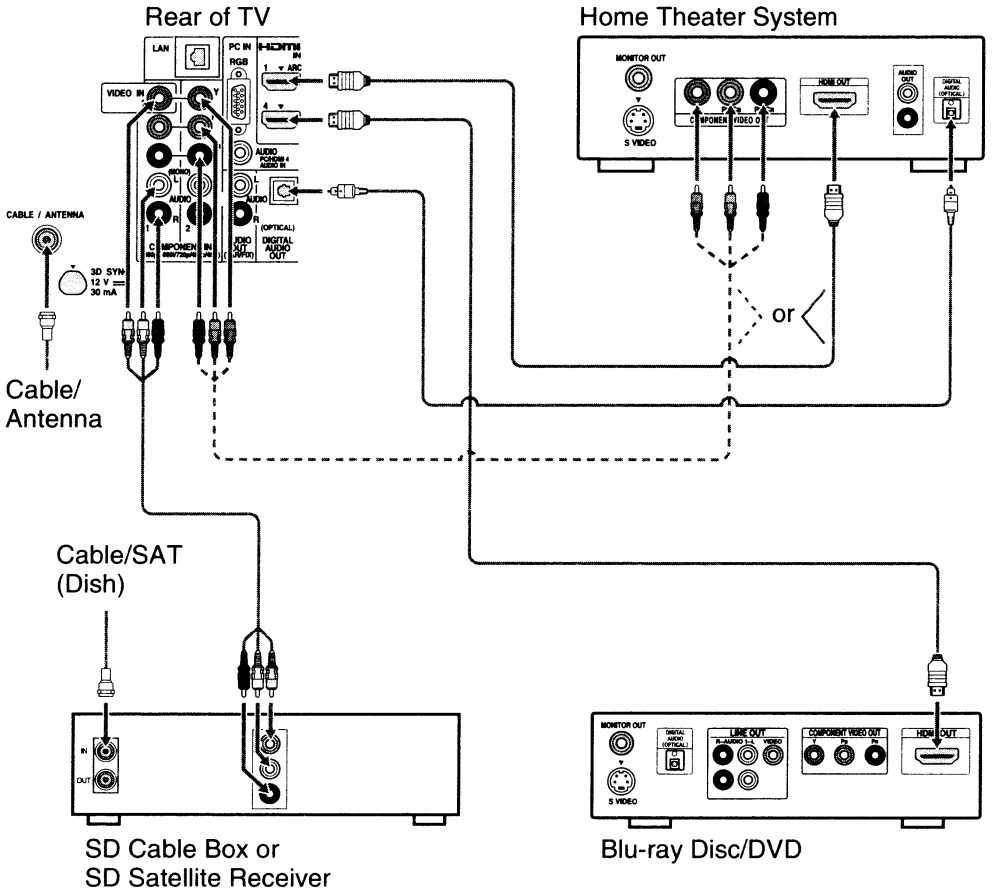

# Shown with PC Connection with SD VCR/DVD

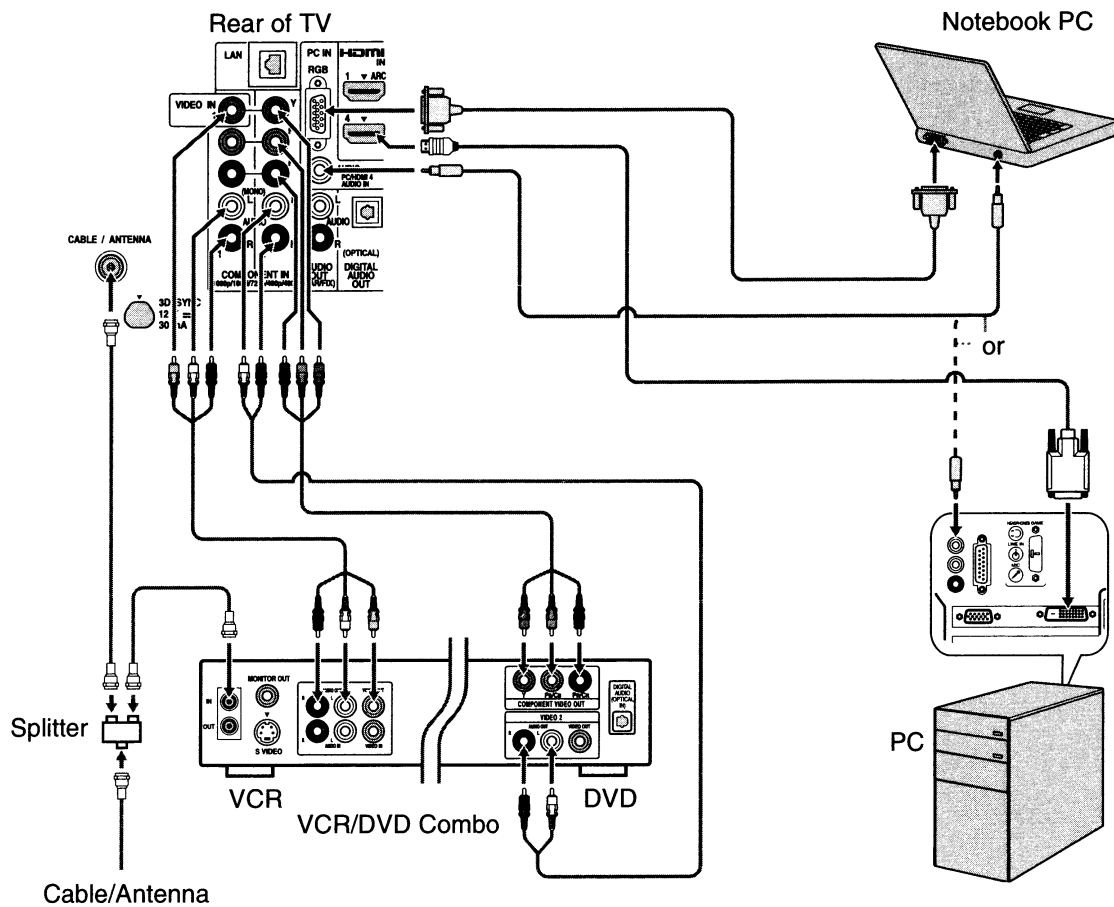

Setting up your TV

## Securing the TV



Sony strongly recommends taking measures to prevent the TV from toppling over. Unsecured TVs may topple and result in property damage, serious bodily injury or even death.

## Preventing the TV from Toppling

- Secure the TV to a wall and/or stand.
- Do not allow children to play or climb on furniture and TV sets.
- Avoid placing or hanging items on the TV.
- Never install the TV on:
  - slippery, unstable and/or uneven surfaces.
  - furniture that can easily be used as steps, such as a chest of drawers.
- Install the TV where it cannot be pulled, pushed, or knocked over.
- Route all AC power cords and connecting cables so that they are not accessible to curious children.

## Recommended Measures to Secure the TV

Consider the following measures when securing your TV to a Stand (not supplied).

### 1 Secure the Stand for the TV

Make sure the Stand can adequately support the weight of the TV. Use two angle braces (not supplied) to secure the stand. For each angle brace use the appropriate hardware to:

- Attach one side of the angle brace to the wall stud.
- Attach the other side to the Stand.

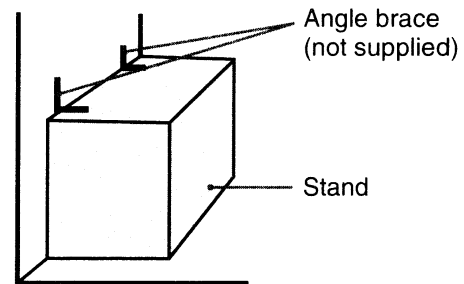

### 2 Secure the TV to the Stand

Use the optional hardware listed below (not supplied):

- M4 × 16 machine screw (screwed into the TV's Table-Top Stand)
- A screw or similar (attach it to the Stand)
- Rope or chain (strong enough to support the weight of the TV). Make sure that there is no excess slack in the rope or chain.

An alternative way to secure the TV is with an optional Sony Support Belt Kit.

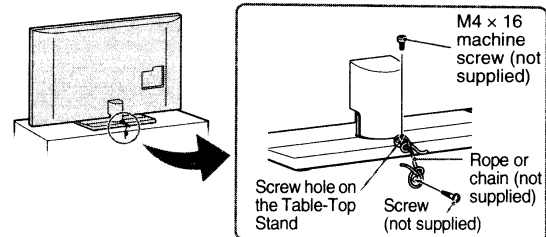

Contact Sony Customer Support to obtain the optional Support Belt Kit by providing your TV model name.

- For United States call: 1-800-488-7669 or visit: [www.sony.com/accessories](http://www.sony.com/accessories)
- For Canada call: 1-877-899-7669

### 3 Anchor the TV to the Wall

Anchor the TV to the wall by using bolts, wall anchor and chain (or rope).

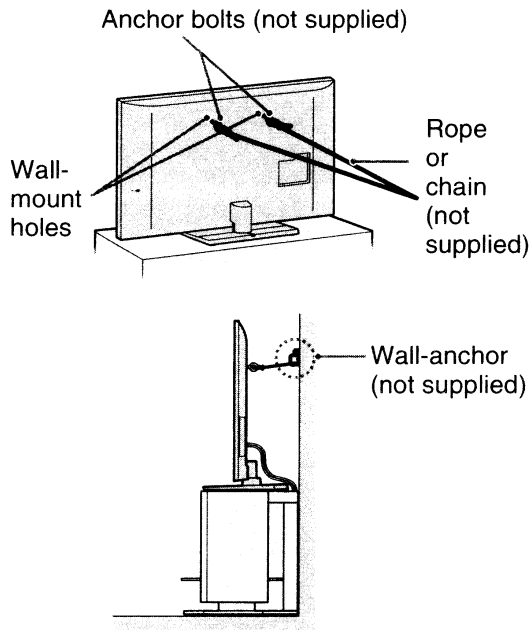

### Organizing the AC power cord

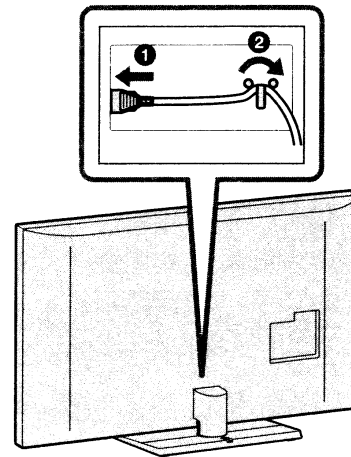

- KDL-55HX800 is shipped with screws attached to the rear of the TV. (They are fastened in the screw holes for wall mounting.) Be sure to remove the upper two screws prior to installing the TV on a wall.
- Securing the TV to the stand without securing the TV and the stand to the wall provides minimum protection against the TV toppling over. For further protection, be sure to follow the three measures recommended.

## Running initial setup

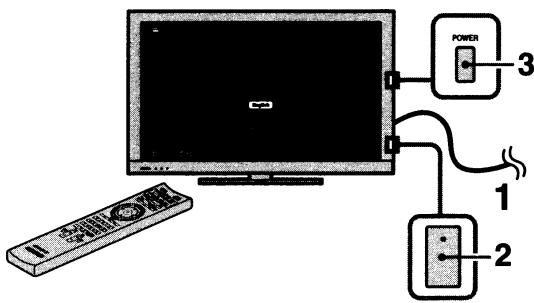

- 1** Complete your cable connections before proceeding with the **Initial Setup**.  
Connect the TV to your nearest power outlet.
- 2** Check the **ENERGY SAVING SWITCH** setting is on (●).
- 3** Press **POWER** on the TV.  
When you switch the TV on for the first time, the **Language** menu appears on the screen.

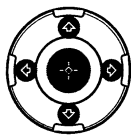

- 4** Follow the instructions on the screen.



- The **ENERGY SAVING SWITCH** must be on (●) to set the clock and obtain program information for the TV Guide.
- **Home** mode sets the TV to settings optimized for home viewing (this setting is ENERGY STAR compliant).

- 5** Select **Continue** to scan for available channels and enable the **TV Guide On Screen®** feature. If you receive channels from a cable box or satellite receiver and do not wish to use the TV's built-in tuner, select **Skip**.  
Selecting **Skip** will disable the **TV Guide On Screen** feature, which is only available when the TV's tuner is used.



- If you skip the channel scan while in the setup menus, TV Guide will be disabled.

## Detaching the Table-Top Stand from the TV

Remove only the screws marked with ↑ on the TV.

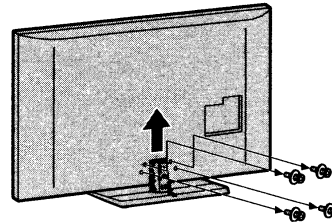

- Do not remove the Table-Top Stand for any reason other than to install corresponding accessories on the TV.
- For XBR-52/46HX909 and KDL-40HX800, remove the stand rear cover prior to detaching the Table-Top Stand.
- For KDL-55HX800, when installing the TV on a wall, remove the four screws from the rear of the TV. (They are fastened in the screw holes for wall mounting.) Be sure to store the removed screws in a safe place, keeping them away from children.
- For KDL-55HX800, when attaching the Table-Top Stand again, be sure to fasten the four screws (previously removed) to the original holes on the rear of the TV.
- Do not hold by the stand rear cover while carrying the Table-Top Stand to prevent dropping the stand which may cause an injury or damage to the property.

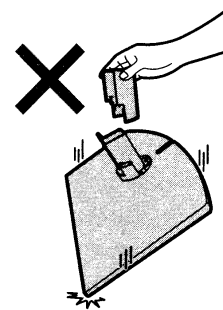

## Using a Wall-Mount Bracket

Your TV can be mounted on a wall using a Wall-Mount Bracket (not supplied) out of the box as packaged. If the Table-Top Stand is attached to the TV, the TV may require detaching the Table-Top Stand; see “Detaching the Table-Top Stand from the TV” (page 14). Prepare the TV for the Wall-Mount Bracket before making cable connections.

**For product protection and safety reasons, Sony strongly recommends that you use the Wall-Mount Bracket designed for your TV and the installation should be performed by a Sony dealer or licensed contractor.**

- Follow the instruction guide provided with the Wall-Mount Bracket for your model. Sufficient expertise is required in installing this TV, especially to determine the strength of the wall for withstanding the TV’s weight.

- Be sure to use the screws supplied with the Wall-mount bracket when attaching the mounting hooks to the TV set.

The supplied screws are designed so that they are 8 mm to 12 mm in length when measured from the attaching surface of the mounting hook.

The diameter and length of the screws differ depending on the Wall-mount bracket model. Use of screws other than those supplied may result in internal damage to the TV set or cause it to fall, etc.

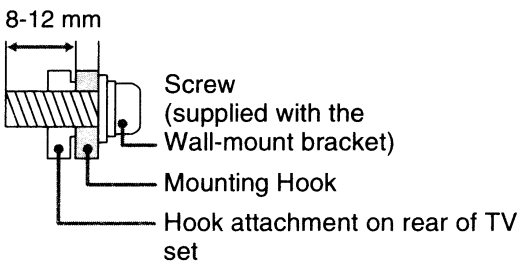

- Be sure to store the unused screws and Table-Top Stand in a safe place until you are ready to attach the Table-Top Stand. Keep the screws away from small children.



- Read the supplied Safety Booklet for additional safety information.

## Installing the TV Against a Wall or Enclosed Area

Make sure that your TV has adequate ventilation. Allow enough space around the TV as shown below. Avoid operating the TV at temperatures below 41 °F (5 °C).

### Installed with stand

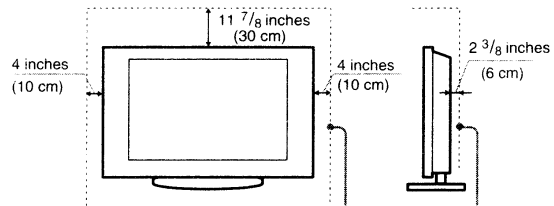

Leave at least this much space around the set.

### Installed on the wall

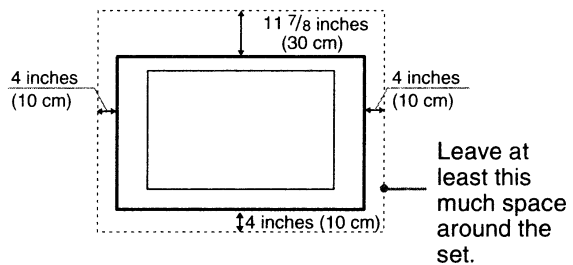

Never install the TV set as follows:

Air circulation is blocked. Air circulation is blocked.

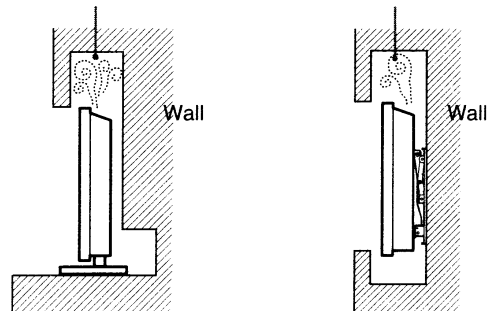

- Inadequate ventilation can lead to overheating of the TV and may cause damage to your TV or cause a fire.

# To watch TV

## To watch programs

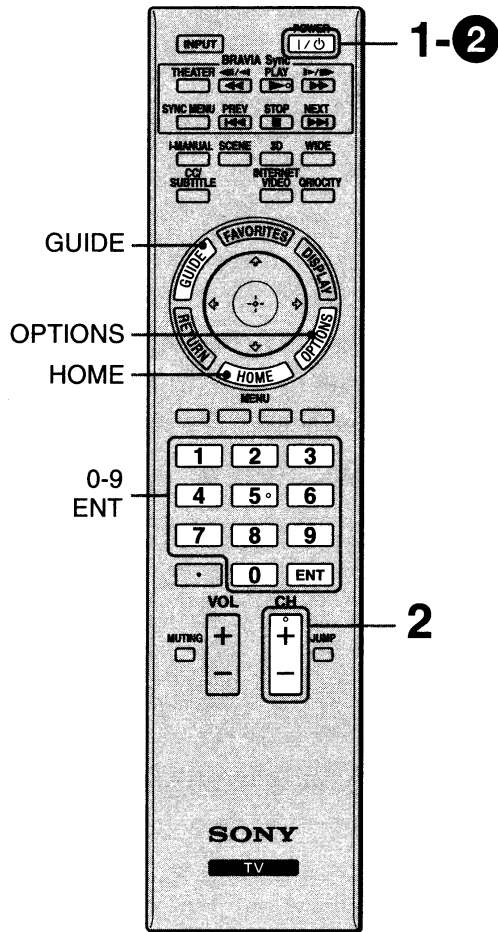

### 1 Turn on the TV.

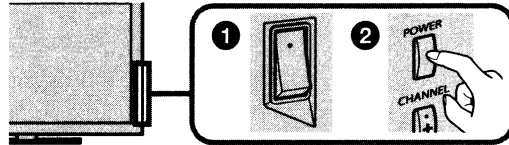



- 1 Check the **ENERGY SAVING SWITCH** setting is on (●).
- 2 Press **POWER** on the TV or on the remote control to turn on the TV. (You may use the  button located on the front or back of the remote control.)

### 2 Select a TV channel.



#### To use the Guide

Press **GUIDE** to display the **TV Guide On Screen** to view scheduled programs or to select a program to watch. Press again to exit the Guide. Use with **0-9** and **ENT** to select digital channels. For example, to enter 2.1, press , ,  and **ENT**.



## To use the TV features

Press **HOME** to display **TV Home Menu/XMB™** to access **TV Settings** and other media and network related content.



Press **OPTIONS** to display a list of convenient functions and menu shortcuts. The Options menu items vary based on current input and/or content.



## To use i-Manual

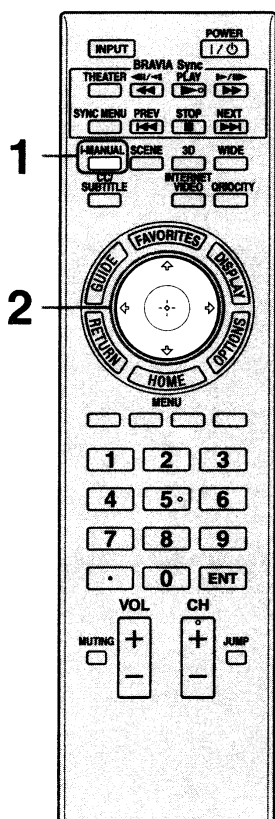

Your **BRAVIA** TV comes with an on-screen manual. To learn more about your TV's features you can access your i-Manual with the touch of a button.

### 1 Press i-MANUAL.



### 2 Press $\uparrow/\downarrow/\leftarrow/\rightarrow/\oplus$ to navigate and select items.

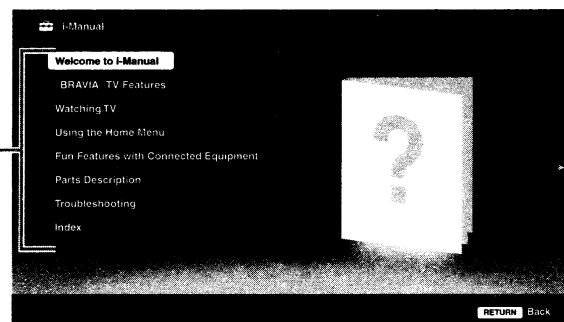
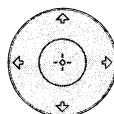

To watch TV

#### ■ Welcome to i-Manual

#### ■ “BRAVIA” TV Features

#### ■ Watching TV

Introduces convenient features such as TV Guide, Favorites, etc.

#### ■ Using the Home Menu

You can find how to customize your TV settings, etc.

#### ■ Fun Features with Connected Equipment

Introduces how to connect and enjoy optional equipment.

#### ■ Parts Description

#### ■ Troubleshooting

You can find solutions for your problems.

#### ■ Index



- Images and illustrations may differ from what you are watching on this TV.

# Troubleshooting

The TV will indicate any problems with the **STANDBY** indicator flashing in red.

## When the **STANDBY** indicator is flashing

The self-diagnosis function is activated.

- 1 Count how many times the **STANDBY** indicator flashes between each three second break.  
For example, the indicator may flash three times, go off for three seconds, then flash again three times.
- 2 Press **POWER** on the TV to turn it off, disconnect the AC power cord, and contact Sony Customer Support (information provided on the front cover) with how many times the indicator flashes.

## When the **STANDBY** indicator is not flashing

- 1 Check the items in the tables below. (Also refer to “Troubleshooting” in the i-Manual.)
- 2 If the problem persists, contact Sony Customer Support (information provided on the front cover).

Condition	Explanation/Solution
<b>Picture</b>	
There is no picture (screen is dark) and no sound.	<ul style="list-style-type: none"><li>• Check the antenna/cable connection.</li><li>• Connect the TV to the AC power, and press <b>POWER</b> on the TV.</li><li>• If the <b>STANDBY</b> indicator lights up in red, press <b>POWER</b> on the remote control.</li></ul>
Tiny black dots and/or bright dots appear on the screen.	<ul style="list-style-type: none"><li>• The screen is composed of pixels. Tiny black dots and/or bright dots (pixels) on the screen do not indicate a malfunction.</li></ul>
<b>General</b>	
The TV's power cannot be turned on.	<ul style="list-style-type: none"><li>• Check to see the (●) mark on the <b>ENERGY SAVING SWITCH</b> is pressed.</li></ul>
The TV turns off automatically (the TV enters standby mode).	<ul style="list-style-type: none"><li>• Check if the <b>Sleep Timer, Timer, or Idle TV Standby</b> is activated.</li><li>• The <b>Auto Shut-off</b> function may be set to <b>On</b>. If <b>Auto Shut-off</b> is activated and TV receives no signal, the TV will automatically enter standby mode in 15 minutes. Check <b>Auto Shut-off</b> is activated under <b>Eco</b> feature of this TV.</li></ul>
The remote does not function.	<ul style="list-style-type: none"><li>• Replace the batteries.</li><li>• Your TV may be in <b>SYNC</b> mode. Press <b>SYNC MENU</b>, select <b>TV Control</b> and then select <b>Home (Menu)</b> or <b>Options</b> to control the TV.</li></ul>
The TV and its surrounding become warm.	<ul style="list-style-type: none"><li>• When the TV is used for an extended period of time, the TV and its surround may become warm to touch. This is not malfunction of the TV.</li></ul>
The <b>Parental Lock</b> password has been forgotten.	<ul style="list-style-type: none"><li>• Enter 4357 for the PIN code. (PIN code 4357 is always accepted.)</li></ul>

---

## How to Care for Your BRAVIA

Safety is very important, please read and follow the safety documentation (Safety Booklet) separately provided.

Unplug the TV and other connected equipment from the wall outlet before you begin cleaning your TV.

- Wipe the LCD screen gently with a soft cloth.
- Stubborn stains may be removed with a cloth slightly moistened with a solution of mild soap and warm water.
- If using a chemically pretreated cloth, please follow the instruction provided on the package.
- Never use strong solvents such as a thinner, alcohol or benzine for cleaning.
- Do not plug in the TV into the wall outlet until the moisture from cleaning has evaporated.

The TV should also be placed on a stable surface to prevent it from toppling over (see page 12).

If you have young children or pets at home, check regularly to insure the TV is securely fastened.

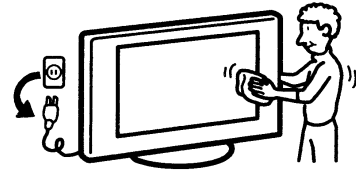

# Specifications

System	
Television system	NTSC: American TV standard ATSC (8VSB terrestrial): ATSC compliant 8VSB QAM on cable: ANSI/SCTE 07 2000 (Does not include CableCARD functionality)
Channel coverage	Analog terrestrial: 2 - 69 / Digital terrestrial: 2 - 69 Analog Cable: 1 - 135 / Digital Cable: 1 - 135
Panel system	LCD (Liquid Crystal Display) Panel
Speaker output	10 W + 10 W
Input/Output jacks	
CABLE/ANTENNA	75-ohm external terminal for RF inputs
VIDEO IN 1/2	VIDEO / AUDIO
COMPONENT IN 1/2	YPBPR (Component Video) / Signal format: 480i, 480p, 720p, 1080i, 1080p / AUDIO
HDMI IN 1/2/3/4	HDMI: Video: 480i, 480p, 720p, 720/24p, 1080i, 1080p, 1080/24p Audio: Two channel linear PCM 32, 44.1 and 48 kHz, 16, 20 and 24 bits, Dolby Digital AUDIO (HDMI IN 4)
AUDIO OUT	500 mVrms (typical)
DIGITAL AUDIO OUT (OPTICAL)	PCM/Dolby Digital optical signal
PC IN	D-sub 15-pin, analog RGB
PC/HDMI 4 AUDIO INPUT	Stereo mini jack
LAN	10BASE-T/100BASE-TX connector (Connection speed may differ depending on the network environment. 10BASE-T/100BASE-TX communication rate and communication quality are not guaranteed for this TV.)*1
USB/DLNA	Refer to the i-Manual for supported format.
3D SYNC	3D Sync terminal for optional transmitter
REMOTE (HX909 series only)	RS232C, D-sub 9 pin. This jack is for receiving the external control signal.

Model name KDL-/XBR-	55HX800	52HX909	46HX909	46HX800	40HX800
Power and others					
Power requirement	110 V - 240 V AC, 50/60 Hz (U.S.A./Canada 120 V AC, 60 Hz)				
Power consumption in use	167 W	201 W	184 W	149 W	132 W
in DAM*2	14 W (You may hear a clicking noise during the download but this is normal.)				
in standby	Less than 0.12 W with 120 V AC and less than 0.2 W with 240 V AC				
Screen size (inches measured diagonally)	54.6 inches (55 class)	52 inches	46 inches		40 inches
Display resolution	1,920 dots (horizontal) × 1,080 lines (vertical)				
Speaker Full range with speaker box (2)	34 × 160 mm 1 3/8 × 6 3/8 inches	34 × 100 mm 1 3/8 × 4 inches		34 × 160 mm 1 3/8 × 6 3/8 inches	
Dimensions with stand	1,278 × 797 × 350 mm 50 3/8 × 31 1/2 × 13 7/8 inches	1,263 × 807 × 400 mm 49 3/4 × 31 7/8 × 15 3/4 inches	1,124 × 727 × 400 mm 44 3/8 × 28 5/8 × 15 3/4 inches	1,085 × 688 × 260 mm 42 3/4 × 27 1/8 × 10 1/4 inches	952 × 613 × 250 mm 37 1/2 × 24 1/4 × 9 7/8 inches
without stand	1,278 × 765 × 73 mm 50 3/8 × 30 1/8 × 2 7/8 inches	1,263 × 775 × 67 mm 49 3/4 × 30 5/8 × 2 3/4 inches	1,124 × 695 × 67 mm 44 3/8 × 27 3/8 × 2 3/4 inches	1,085 × 656 × 74 mm 42 3/4 × 25 7/8 × 3 inches	952 × 581 × 74 mm 37 1/2 × 22 7/8 × 3 inches
wall-mount hole pattern	400 × 300		300 × 300		
wall-mount screw size	M6 (length: refer to diagram on page 15.)				
Mass with stand	26.9/59.3 (kg)/(lb.)	42.9/94.5	36.2/79.8	19.2/42.3	16.4/36.2
without stand	22.6/49.8	36.9/81.3	30.2/66.6	16.9/37.3	14.2/31.3
Supplied accessories	See "Checking the accessories" (page 4).				
Optional accessories	Connecting cables / Support Belt Kit / Wall-Mount Bracket / TV Stand / 3D Glasses (TDG-BR100/TDG-BR50) / 3D Sync Transmitter (TMR-BR100)				

\*1 For LAN connections, use a Category 7 10BASE-T/100BASE-TX cable (not supplied).

\*2 Download Acquisition Mode (DAM) is used for software updates and/or collecting data for TV Guide On Screen.

- Optional accessories availability depends on its stock.
- Design and specifications are subject to change without notice.

### Declaration of Conformity

Trade Name: SONY  
Model: KDL-55HX800/XBR-52HX909/XBR-46HX909/  
KDL-46HX800/KDL-40HX800  
Responsible Party: Sony Electronics Inc.  
Address: 16530 Via Esprillo,  
San Diego, CA 92127 U.S.A.  
Telephone Number: 858-942-2230

This device complies with part 15 of the FCC rules.  
Operation is subject to the following two conditions:  
(1) This device may not cause harmful interference, and  
(2) this device must accept any interference received,  
including interference that may cause undesired  
operation.

### For customers in Canada

This Class B digital apparatus complies with Canadian ICES-003.

### FCC Related Information

This equipment has been tested and found to comply with the limits for a Class B digital device, pursuant to Part 15 of the FCC Rules. These limits are designed to provide reasonable protection against harmful interference in a residential installation. This equipment generates, uses and can radiate radio frequency energy and, if not installed and used in accordance with the instructions, may cause harmful interference to radio communications. However, there is no guarantee that interference will not occur in a particular installation. If this equipment does cause harmful interference to radio or television reception, which can be determined by turning the equipment off and on, the user is encouraged to try to correct the interference by one or more of the following measures:

- Reorient or relocate the receiving antenna.
- Increase the separation between the equipment and receiver.
- Connect the equipment into an outlet on a circuit different from that to which the receiver is connected.
- Consult the dealer or an experienced radio/TV technician for help.

Pursuant to FCC regulations, you are cautioned that any changes or modifications not expressly approved in this manual could void your authority to operate this equipment.

### Note

This television includes a QAM demodulator which should allow you to receive unscrambled digital cable television programming via subscription service to a cable service provider. Availability of digital cable television programming in your area depends on the type of programming and signal provided by your cable service provider.

### Compatible Optional Accessories Information

Use the following Sony optional accessories with your TV model.

	Sony TV Model No.			
KDL-/XBR-	55HX800	52HX909	46HX909	46HX800/ 40HX800
Sony Wall-Mount Bracket Model No.	SU-WL500			
Sony TV Stand No.*	—	SU-52HX1	SU-46HX1	—

\* Some of these TV Stand models may not be available in your area.

Use with other optional accessories may cause instability and could result in property damages or injury.

For instructions on using the Wall-Mount bracket with your TV please go to <http://esupport.sony.com> for your TV model and download "Additional Information for Using Sony Wall-Mount Bracket".

### To Customers

Sufficient expertise is required for TV installations. Be sure to subcontract the installation to a Sony dealer or licensed contractor and pay adequate attention to safety during the installation.

## For Your Convenience

### Online Registration:

Be sure to register your TV.

**United States**     <http://productregistration.sony.com>

**Canada**             <http://www.SonyStyle.ca/registration>

### Software Updates:

Your TV is capable of receiving software updates. For the latest information about software updates for your TV, visit:

**United States**     <http://www.sony.com/tvsupport>

**Canada**             <http://www.sony.ca/support>

**NOTE:** If your TV is connected to the Internet, you can check for software updates by selecting **Settings, Product Support** and then **Automatic Software Update**.

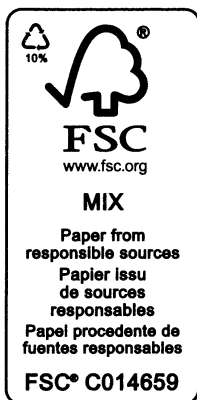

<http://www.sony.net/>

© 2010 Sony Corporation Printed in U.S.A.



4180193111

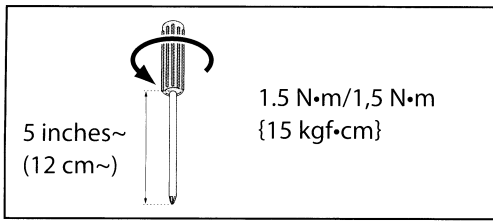

**1** ~40"

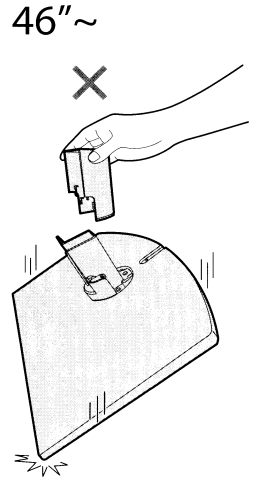
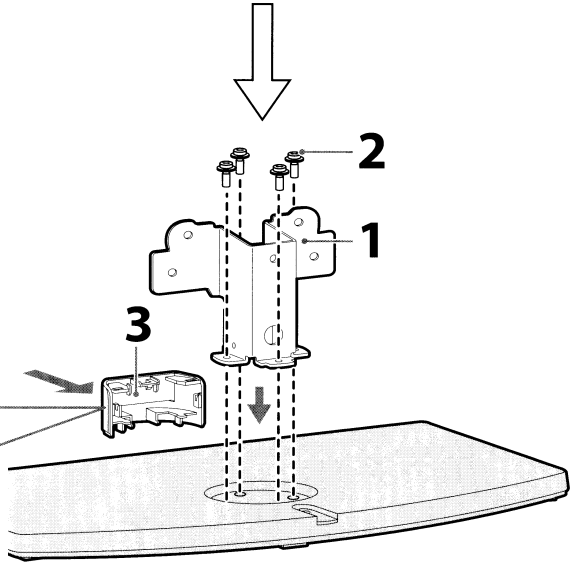
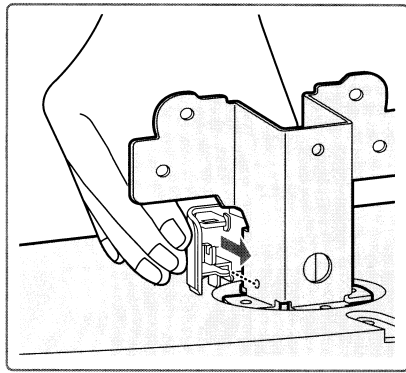

**2**

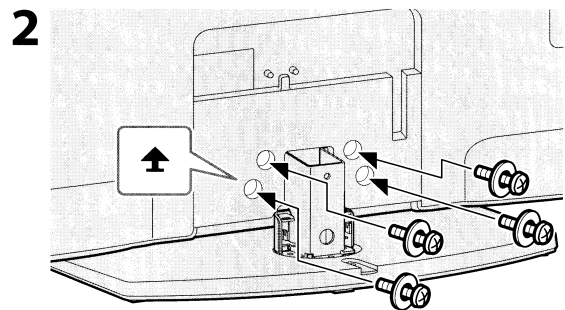
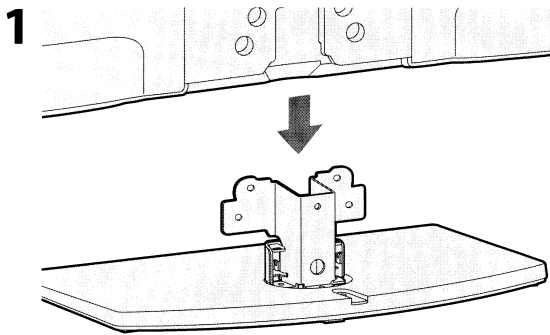

**3**

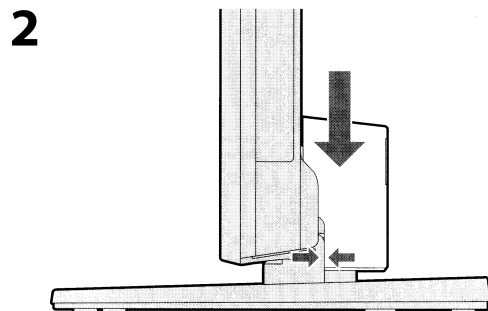
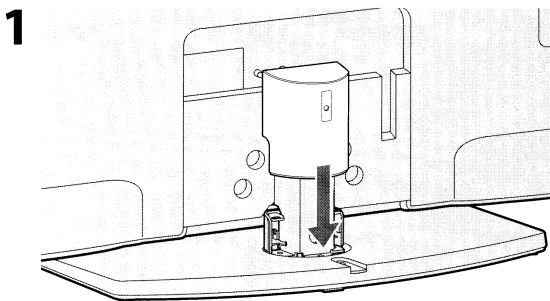

~40"

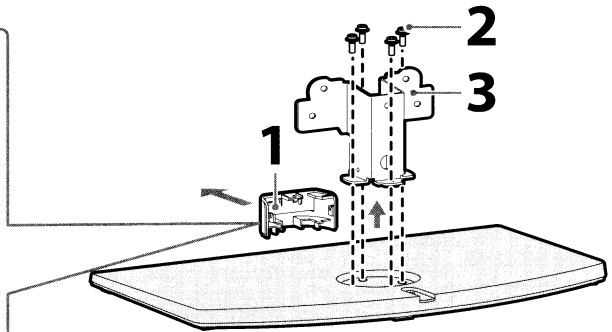
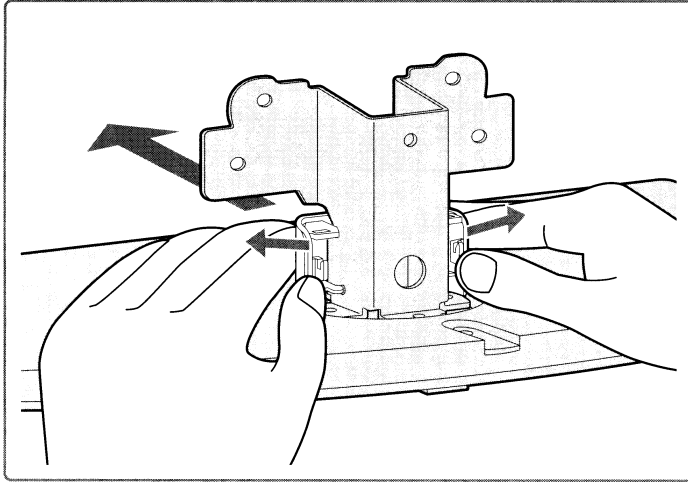

**SONY**

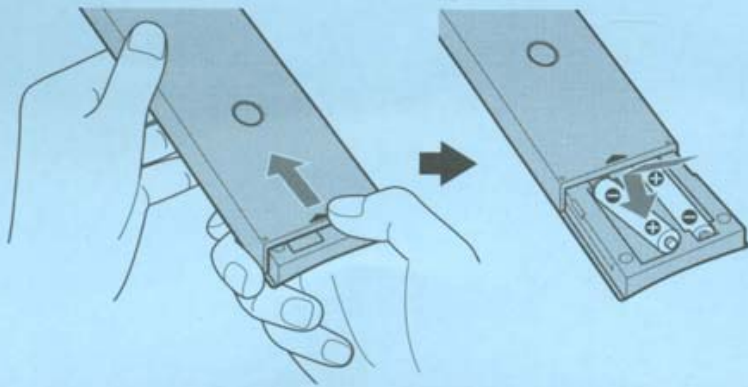

Slide the cover to open.

Deslize a tampa para abrir.

Deslice la cubierta para abrirla.

Verschuif de afdekking om te openen.

Ouvrez le couvercle en le faisant glisser.

Verschieben Sie zum Öffnen die Abdeckung.

Per aprire, far scorrere il coperchio verso l'alto.

滑动并打开盖子。

滑動並打開蓋子。

커버를 밀어서 엽니다.

# SONY®

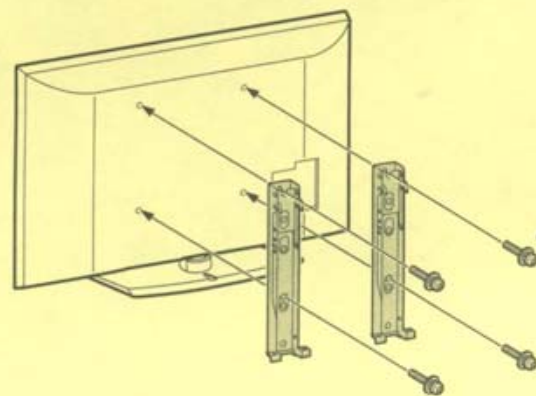

**8 mm - 12 mm**

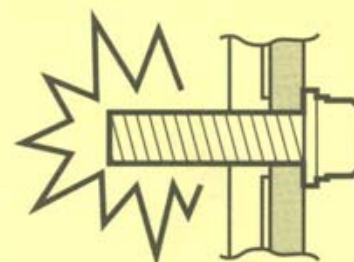
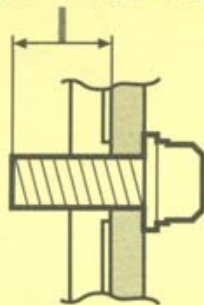

## US CAUTION

When using a non-Sony Wall-mount bracket, be sure to use fixing screws which are **8 mm to 12 mm** in length when measured from the attaching surface of the mounting hook. Use of fixing screws other than those specified may result in internal damage to the TV set or cause the TV to fall, etc. (The images shown are examples. Your TV model/Wall-mount bracket may differ.)

## FR ATTENTION

Lors de l'utilisation d'un support de montage mural de marque autre que Sony, veuillez à utiliser des vis mesurant de **8 mm à 12 mm** à partir de la surface de fixation du crochet de montage. L'utilisation d'autres vis que celles qui sont indiquées peut occasionner des dommages internes au téléviseur ou causer sa chute, etc. (Les illustrations sont fournies à titre d'exemples. Votre téléviseur ou le support de fixation murale peuvent être différents, selon le modèle.)

## ES PRECAUCIÓN

Cuando use un soporte para pared que no sea Sony, asegúrese de usar tornillos de fijación de **8 mm a 12 mm** de largo cuando se miden desde la superficie de sujeción del gancho de montaje. El uso de tornillos de fijación que no sean los especificados puede causar daños al equipo de televisión o hacer que el televisor se caiga, etc. (Las imágenes que se muestran son ejemplos. Su modelo de televisor/montaje de pared puede ser diferente.)

## PT CUIDADO

Quando utilizar um suporte de montagem que não é da marca Sony, certifique-se de utilizar parafusos de fixação de **8 mm a 12 mm** de comprimento quando medido a partir da superfície de fixação do gancho de montagem. A utilização de parafusos de fixação do tipo não especificado pode resultar em danos internos da TV ou causar a sua queda, etc. (A imagem mostrada é meramente ilustrativa. O modelo da sua TV/suporte de montagem pode ser diferente.)



4 191201121

4-191-201-12(1)

# Connecting other equipment

## Internet Settings

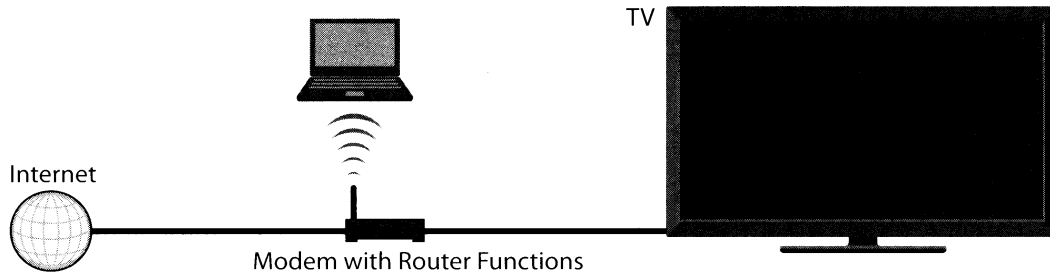

## Connecting to the Internet

Using the network feature you can connect the TV to the Internet. The setup procedure differs depending on the type of network and LAN router.

Before setting up the Internet connection:

- Be sure to set up a LAN router.
- Check your wireless LAN environment using the following chart. If you have a wired network environment, directly refer to (4).

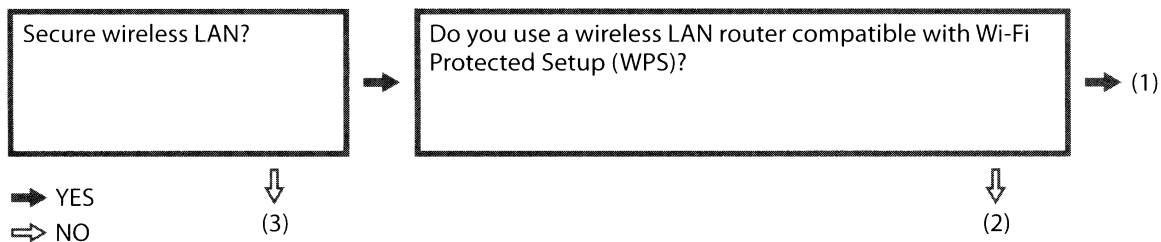

- (1) ▶ Follow the configuration for “Network Setup” and “Secured Network with Wi-Fi Protected Setup (WPS).”
- (2) ▶ Follow the configuration for “Network Setup” and “Secured Network without Wi-Fi Protected Setup (WPS).”
- (3) ▶ Follow the configuration for “Network Setup” and “Unsecured Network with Any Type of Wireless LAN Router.”
- (4) ▶ Refer to “Network Setup” and follow the instructions that appear on the screen.

## Network Setup

“Network Setup” helps you configure network settings with the settings wizard. Follow the instructions on the screen.

Press HOME, then select > Network > Network Setup.

The start-up screen allows you to select a setting procedure according to your network environment.

“View Network Status”: Select to confirm your network status.

“Wired Setup”: Use to connect to a wired network.

“Wireless Setup”: Use to connect to a wireless network.

---

## Secured Network with Wi-Fi Protected Setup (WPS)

The WPS standard makes setup of a secure wireless home network as simple as pressing the WPS button on the wireless LAN router. Before setting up a wireless LAN, check the location of the WPS button on the router and verify how to use it.

- 1 Select “Wireless Setup” from the “Network Setup” start-up screen.
- 2 Select “WPS (Push Button)” for Push Button method or “WPS (PIN)” for PIN method.
- 3 Follow the instructions that appear on the setup screen.



- To connect to a wireless LAN with WPS, your wireless LAN router needs to support the WPS standard.

---

## Secured Network without Wi-Fi Protected Setup (WPS)

For setting up a wireless LAN, SSID (wireless network name) and security key (WEP or WPA key) will be required. If you do not know them, consult the instruction manual of your router.

- 1 Select “Wireless Setup” from the “Network Setup” start-up screen.
- 2 Select “Scan,” then select a network from the list of scanned wireless networks.
- 3 Follow the instructions that appear on the setup screen.

---

## Unsecured Network with Any Type of Wireless LAN Router

For setting up a wireless LAN, SSID (wireless network name) will be required. Security key (WEP or WPA key) will not be required because you need to select no security method in this procedure.

- 1 Select “Wireless Setup” from the “Network Setup” start-up screen.
- 2 Select “Scan,” then select a network from the list of scanned wireless networks.
- 3 Follow the instructions that appear on the setup screen.

---

## Checking the Network Connection

Enter the respective alphanumeric values for your router if necessary. The items that need to be set (e.g. IP Address, Subnet Mask, DHCP) may differ depending on the Internet service provider or router. For details, refer to the instruction manuals provided by your Internet service provider, or those supplied with the router.

- 1 Select “Auto” to set the IP Address and proxy server automatically, or “Custom” to set them manually.
- 2 Follow the instructions that appear on the setup screen.

## Wireless LAN Ready

Wireless LAN Ready lets you easily access the Internet and your home network with the USB Wireless LAN Adapter UWA-BR100 (as of January 2010). By inserting the USB Wireless LAN Adapter into your TV's USB port, you can easily create a cable-free network.

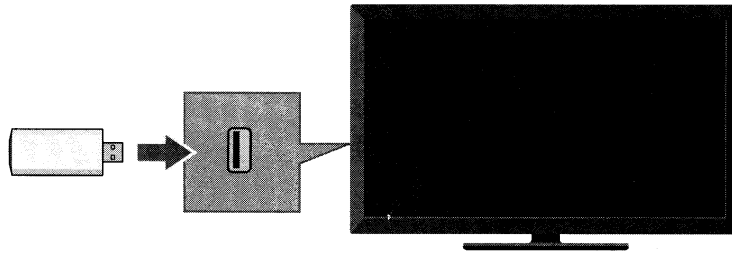

- Before setting up the wireless LAN function of the TV, be sure to set up a wireless LAN router.
- The USB Wireless LAN Adapter is supplied or available as an optional accessory, depending on your TV model. In some regions/countries, the USB Wireless LAN Adapter may not be available.

## Built-in Wireless LAN (Built-in Wireless LAN model only)

The built-in Wireless LAN device allows you to access the Internet and your home network. With this feature, you can easily connect to a wireless LAN and enjoy the benefits of networking in a cable-free environment.

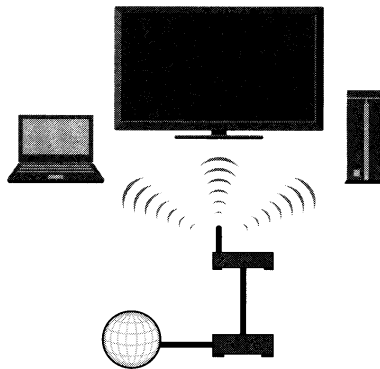

- Before setting up the wireless LAN function of the TV, be sure to set up a wireless LAN router.

## Connecting to Your Wireless LAN

Using the Wireless LAN Ready feature you can connect the TV to your wireless LAN. The setup procedure differs depending on the type of wireless LAN and wireless LAN router.

Before setting up a wireless LAN, check your wireless LAN environment using the following chart.

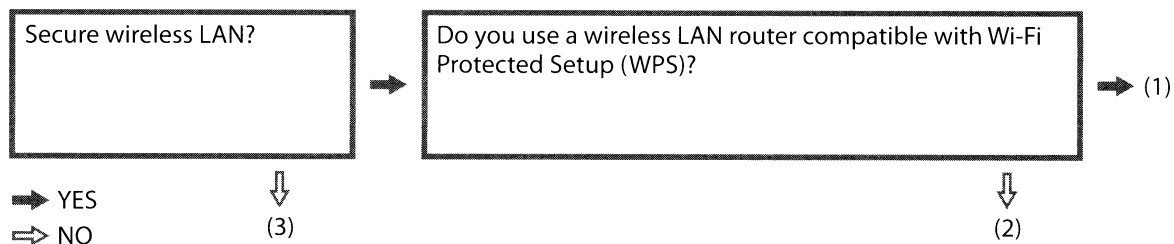

- (1) ▶ Follow the configuration for "Network Setup" and "Secured Network with Wi-Fi Protected Setup (WPS)."
- (2) ▶ Follow the configuration for "Network Setup" and "Secured Network without Wi-Fi Protected Setup (WPS)."
- (3) ▶ Follow the configuration for "Network Setup" and "Unsecured Network with Any Type of Wireless LAN Router."

---

## Network Setup

“Network Setup” helps you configure network settings with the settings wizard. Follow the instructions on the screen.

Press HOME, then select  > Network > Network Setup.

The start-up screen allows you to select a setting procedure according to your network environment.

“View Network Status”: Select to confirm your network status.

“Wired Setup”: Use to connect to a wired network.

“Wireless Setup”: Use to connect to a wireless network.

---

## Secured Network with Wi-Fi Protected Setup (WPS)

The WPS standard makes setup of a secure wireless home network as simple as pressing the WPS button on the wireless LAN router. Before setting up a wireless LAN, check the location of the WPS button on the router and verify how to use it.

- 1 Select “Wireless Setup” from the “Network Setup” start-up screen.
- 2 Select “WPS (Push Button)” for Push Button method or “WPS (PIN)” for PIN method.
- 3 Follow the instructions that appear on the setup screen.



- To connect to a wireless LAN with WPS, your wireless LAN router needs to support the WPS standard.

---

## Secured Network without Wi-Fi Protected Setup (WPS)

For setting up a wireless LAN, SSID (wireless network name) and security key (WEP or WPA key) will be required. If you do not know them, consult the instruction manual of your router.

- 1 Select “Wireless Setup” from the “Network Setup” start-up screen.
- 2 Select “Scan,” then select a network from the list of scanned wireless networks.
- 3 Follow the instructions that appear on the setup screen.

---

## Unsecured Network with Any Type of Wireless LAN Router

For setting up a wireless LAN, SSID (wireless network name) will be required. Security key (WEP or WPA key) will not be required because you need to select no security method in this procedure.

- 1 Select “Wireless Setup” from the “Network Setup” start-up screen.
- 2 Select “Scan,” then select a network from the list of scanned wireless networks.
- 3 Follow the instructions that appear on the setup screen.

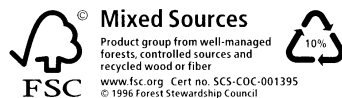

### ENGLISH

#### Preventing TV Tip-Over Accidents

The U.S. Consumer Product Safety Commission (CPSC) estimates that in 2005 at least 3,000 children younger than age 5 were treated in U.S. hospitals emergency rooms because of injuries associated with TV tip-overs. In addition, from 2000 through 2005, CPSC received reports of 36 TV tip-over deaths. More than 80 percent of all these deaths involved young children. The injuries and deaths frequently take place when kids climb onto, fall against or pull themselves up on shelves, bookcases, dressers, desks, chests and television stands. In some cases, televisions placed on top of furniture tip over and cause a child to suffer a traumatic and sometimes fatal injury.

### FRANÇAIS

#### Éviter les accidents de renversement de téléviseur

La commission de surveillance des produits de consommation (CPSC) des É.-U. estime qu'en 2005 au moins 3 000 enfants de moins de cinq ans ont été traités dans les salles d'urgence des hôpitaux états-uniens pour des blessures associées à des renversements de téléviseurs. De plus, de 2000 à 2005, la CPSC a reçu des rapports de 36 décès causés par un renversement de téléviseur. Plus de 80 pour cent de ces décès impliquaient de jeunes enfants. Les blessures et les décès ont souvent lieu lorsque les enfants tombent contre, grimpent ou se hissent sur des tablettes, des bibliothèques, des commodes, des bureaux, des armoires et des supports de téléviseur. Dans certains cas, les téléviseurs placés sur des meubles se renversent et causent une blessure grave et parfois fatale à l'enfant.

### ESPAÑOL

#### Prevención de accidentes por vuelco y caída del televisor

La Comisión de Seguridad de Productos de EE.UU. (CPSC) calcula que en el 2005 por lo menos 3,000 niños menores de 5 años recibieron tratamiento de emergencia en hospitales de Estados Unidos debido a las lesiones recibidas al volcarse un televisor. Asimismo, entre los años 2000 y 2005, la CPSC recibió informes de 36 muertes causadas por volcarse un televisor. Más del 80% de las muertes fueron de niños pequeños. Con frecuencia, las lesiones y muertes suceden cuando un niño se trepa a un televisor, cae sobre él o trata de subirse en repisas, roperos, escritorios o bases de televisor. En algunos casos, cuando se coloca un televisor encima de un mueble, éste puede volcarse y caer causando trauma físico y hasta la muerte en niños.

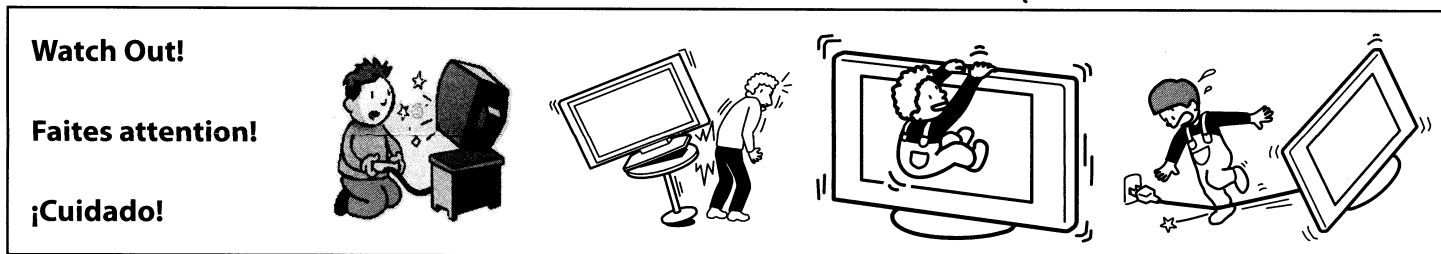

**Watch Out!**

**Faites attention!**

**¡Cuidado!**

#### The following safety tips are recommended to prevent furniture or TV tip-overs:

- Verify that television is placed only on furniture that is stable on its own. For added security it is recommended that you attach to the wall or anchor to the floor all entertainment units, TV stands, bookcases, shelving, and bureaux using appropriate hardware, such as brackets, screws, or toggles.
- Place the television on sturdy furniture appropriate for the size of the TV or on a low-rise base.
- Push the television as far back as possible.
- Place electrical cords and audio/visual cables out of a child's reach, and teach kids not to play with them.
- Remove items that might tempt kids to climb on or near the television, such as toys and remote controls, from top of the TV and furniture.

See the operating instruction for more information on how to secure the TV.

#### Les conseils de sécurité suivants sont recommandés pour éviter les renversements de meubles ou de téléviseurs :

- Assurez-vous que le téléviseur est placé seulement sur un meuble qui est stable par lui-même. Pour augmenter la sécurité, il est recommandé de fixer au mur ou au sol toutes les unités de divertissement, les supports de téléviseur, les bibliothèques, les tablettes et les bureaux au moyen de la quincaillerie appropriée, comme des supports, des vis ou des boulons à ailettes.
- Placez le téléviseur sur un meuble robuste approprié pour la taille du téléviseur ou sur une base basse.
- Poussez le téléviseur aussi loin que possible vers l'arrière.
- Placez les cordons électriques et les câbles audio/vidéo hors de la portée des enfants et montrez-leur de ne pas jouer avec eux.
- Retirez du dessus du téléviseur et des meubles les objets qui pourraient inciter les enfants à grimper sur ou près du téléviseur, comme des jouets ou des télécommandes.

Reportez-vous aux directives d'utilisation pour obtenir d'autres renseignements sur la façon de sécuriser le téléviseur.

#### A continuación se presentan algunos consejos de seguridad recomendados para prevenir el vuelco y la caída de televisores:

- Asegúrese de que el televisor solamente esté colocado sobre muebles que sean estables en sí. Para mayor seguridad, se recomienda que todas las unidades de entretenimiento, bases para televisor, libreros, repisas o burós se sujeten a la pared o al piso usando las ménsulas, tornillos o abrazaderas adecuadas.
- Coloque el televisor en un mueble sólido adecuado al tamaño del aparato o en una base que no sea alta.
- Coloque el televisor lo más atrás del mueble que sea posible.
- Coloque los cables eléctricos y del sistema audiovisual fuera del alcance de los niños y enséñeles a que no deben jugar con cables.
- Retire cualquier objeto como juguetes o controles remoto que esté encima del televisor o del mueble y que pudiera incitar a los niños a treparse en el televisor o cerca de él.

Consulte las instrucciones de funcionamiento para obtener más información sobre cómo asegurar el televisor.

# ENGLISH

## Does your picture quality seem poor? Do you have a cable or satellite box?

Factors other than your TV can affect picture quality.

### 1) Cable or Satellite Set-Top Box (STB)

Request an HD STB from your service provider and review your STB settings.

You may need to adjust your STB audio and picture settings, otherwise you may experience issues such as: Poor picture quality, black bars on the top or sides of the screen, no audio, empty black boxes on the screen.

Contact your service provider if you have any questions on STB usage.

### 2) Broadcaster

The broadcaster controls the quality of the program. Some programs are broadcast in High Definition (HD), while other programs are broadcast in Standard Definition (SD), even on HD stations.

HD broadcast  
Crisp, clear picture

SD broadcast  
Fuzzy picture, often with black bars



Type of content stations can broadcast:

	SD Station	HD Station
SD Content	X	X
HD Content		X
Both HD & SD content		X

SD content on HD channels does not create an HD picture!

### 3) Original Recording Quality

The quality of the picture you see also depends on the type of camera used when the original recording was made.

# FRANÇAIS

## Est-ce que la qualité de votre image semble mauvaise?

### Est-ce que vous avez le câble ou un satellite?

Facteurs autres que votre téléviseur pouvant affecter la qualité de l'image.

### 1) Décodeur de câble ou satellite

Demandez un décodeur HD à votre fournisseur de service et examinez les réglages de votre décodeur.

Vous devrez ajuster les réglages de son et d'image de votre décodeur, sinon vous pourriez constater les problèmes suivants : mauvaise qualité d'image, barres noires dans le haut ou les côtés de l'écran, pas de son, boîtes noires vides à l'écran.

Communiquez avec votre fournisseur de service si vous avez des questions au sujet de l'utilisation du décodeur.

### 2) Télédiffuseur

Le télédiffuseur contrôle la qualité de l'émission.

Certaines émissions sont télédiffusées en haute définition (HD), tandis que d'autres sont télédiffusées en définition standard (SD), même sur des postes HD.

Télédiffusion HD  
Image claire, précise

Télédiffusion SD  
Image floue, souvent avec des barres noires



Type de contenu que les stations peuvent diffuser :

	Stations SD	Stations HD
Contenu SD	X	X
Contenu HD		X
Contenu HD et SD		X

Le contenu SD sur des canaux HD ne crée pas une image HD!

### 3) Qualité de l'enregistrement initial

La qualité de l'image que vous voyez dépend aussi du type de caméra utilisé lors de l'enregistrement initial.

# ESPAÑOL

## ¿La calidad de la imagen no es óptima? ¿Tiene un receptor de cable o satélite?

Existen factores aparte del televisor que pueden afectar la calidad de la imagen.

### 1) Receptores de cable o satélite (Set-Top Box o STB)

Solicite un receptor de alta definición (HD) de la compañía que le ofrece el servicio y cheque la configuración del receptor.

Es posible que necesite ajustar la configuración de audio e imagen de su receptor, de no ser así, podría observar lo siguiente: mala calidad de la imagen, barras negras en la parte superior o en los costados de la pantalla, falta de audio, recuadros negros vacíos en la pantalla.

Comuníquese con la compañía proveedora de servicio si tiene alguna pregunta sobre el uso de su receptor.

### 2) Cadenas transmisoras

La cadena transmisora controla la calidad del programa. Algunos programas se transmiten en alta definición (HD), mientras que otros se transmiten en definición estándar (SD) o hasta en estaciones de alta definición.

Transmisión en Alta Definición (HD)  
Imagen clara y nítida

Transmisión en Definición Estándar (SD)  
Imagen borrosa, con frecuencia aparecen barras negras



Tipo de contenido que las estaciones pueden transmitir:

	Estación SD	Estación HD
Contenido SD	X	X
Contenido HD		X
Contenido tanto HD como SD		X

¡El contenido SD en canales HD no crea una imagen en alta definición!

### 3) Calidad original de la filmación

La calidad de la imagen que ve también depende del tipo de cámara que se usó cuando se hizo la filmación original.

Safety and Regulatory Booklet

Read and understand the contents of this booklet before operating your new TV.

Feuillet de consignes d'utilisation et de sécurité

Veillez lire et vous assurer de comprendre le contenu de ce feuillet avant d'utiliser votre nouveau téléviseur.

Folleto de instrucciones de seguridad

Lea y entienda el contenido de este folleto antes de operar su nuevo televisor.



3-299-071-03(1)



3299071031

© 2008 Sony Corporation  
Printed in U.S.A.

WARNING

To reduce the risk of fire or electric shock, do not expose this TV to rain or moisture.

The TV must never be exposed to dripping, splashing, or spilling liquids of any kind.



This symbol is intended to alert the user to the presence of uninsulated "dangerous voltage" within the TV's enclosure that may be of sufficient magnitude to constitute a risk of electric shock to persons.



This symbol is intended to alert the user to the presence of important operating and maintenance (servicing) instructions in the literature accompanying the TV.

Outdoor Antenna Grounding

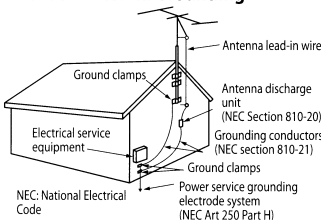

MOISTURE

- Do not place liquid filled objects such as a vase or potted plant on the TV.
- Do not use a power line operated TV set near water; for example, near a bathtub, washbowl, kitchen sink, laundry tub, wet basement or near a swimming pool, etc.



CLEANING

- When cleaning, be sure to unplug the power cord to avoid any chance of electric shock.
- Clean the cabinet of the TV with a dry soft cloth.
- Wipe the LCD screen gently with a soft cloth.
- Stubborn stains may be removed with a cloth slightly moistened with a solution of mild soap and warm water.
- Do not spray water or detergent directly on the TV set. It may drip to the bottom of the screen or exterior parts, and may cause a malfunction.
- If using a chemically pretreated cloth, please follow the instruction provided on the package.
- Never use strong solvents such as a thinner, alcohol or benzine for cleaning.
- Periodic vacuuming of the ventilation openings is recommended to ensure to proper ventilation.



VENTILATION

- The ventilation openings in the TV are necessary to ensure reliable operation of the TV and to protect it from overheating.
- Do not block or cover the ventilation openings with cloth or other materials.
- Never place the TV on a bed, sofa, rug or other similar surface where ventilation openings may be blocked.
- Unless proper ventilation is provided, the TV may accumulate dust and cause damage.
- Never allow liquid or solid objects to fall into the ventilation openings.



- 1) Read these instructions.
- 2) Keep these instructions.
- 3) Heed all warnings.
- 4) Follow all instructions.
- 5) Do not use this apparatus near water.



- 6) Clean only with dry cloth.
- 7) Do not block any ventilation openings. Install in accordance with the manufacturer's instructions.



- 8) Do not install near any heat sources such as radiators, heat registers, stoves, or other apparatus (including amplifiers) that produce heat.



- 9) Do not defeat the safety purpose of the polarized or grounding-type plug. A polarized plug has two blades with one wider than the other. A grounding type plug has two blades and a third grounding prong. The wide blade or the third prong are provided for your safety. If the provided plug does not fit into your outlet, consult an electrician for replacement of the obsolete outlet.

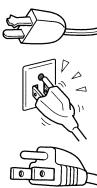

- 10) Protect the power cord from being walked on or pinched particularly at plugs, convenience receptacles, and the point where they exit from the apparatus.

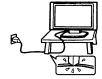

- 11) Only use attachments/accessories specified by the manufacturer.



- 12) Use only with the cart, stand, tripod, bracket, or table specified by the manufacturer, or sold with the apparatus. When a cart is used, use caution when moving the cart/apparatus combination to avoid injury from tip-over.



- 13) Unplug this apparatus during lightning storms or when unused for long periods of time.



- 14) Refer all servicing to qualified service personnel. Servicing is required when the apparatus has been damaged in any way, such as power-supply cord or plug is damaged, liquid has fallen into the apparatus, the apparatus has been exposed to rain or moisture, does not operate normally, or has been dropped.



Please observe the Additional Safety DOs and DON'Ts to avoid electrical shock, short-circuit, fire, bodily injury or property damage.

Additional

- If any liquid or solid object falls inside the TV, unplug the TV immediately and have it checked by qualified service personnel before operating it further.
- Never push objects of any kind into the TV through the ventilation openings as they may come in contact with dangerous voltage points or short out parts that could result in a fire or an electric shock.

Allow adequate space around the TV set to ensure proper air circulation.

- Never place the TV in a confined space, such as a bookcase or built-in cabinet, unless proper ventilation is provided.
- There should be a clearance of at least 11 7/8 inches (30 cm) above the TV set and 4 inches (10 cm) on each side. If mounted on the wall, allow at least 4 inches (10 cm) of clearance at the bottom of the screen. (See additional information provided in the Operating Instructions manual.)



INSTALLATION

The TV should be installed near an easily accessible AC power outlet.

- Do not install the TV face up or down, upside down or on its side.
- Do not install the TV in hot, oily, humid, or excessively dusty places.
- Do not install the TV in places subject to extreme temperature, such as in direct sunlight, near a radiator or a heating vent. The TV may overheat in such conditions which can cause deformation of the enclosure and/or TV malfunction.
- Do not install the TV in a place exposed to direct air conditioning; moisture may condense inside and may cause TV malfunction.
- Do not install the TV where it may be exposed to mechanical vibration.
- Do not install the TV where insects may enter.
- Do not install the TV in a location where it may protrude, such as on or behind a pillar, or any place you might bump your head or receive bodily injury.
- To prevent fire keep flammable objects or open flame (e.g. candles) away from the TV.
- Do not place optional equipment on top of the TV.



Prevent the TV from toppling over

Take measures to prevent the TV from toppling over and causing injury or damage to the TV and property.

- Secure the TV to a wall and/or stand.
- Never install the TV on unstable and/or uneven surfaces.
- Do not allow children to climb on or play with furniture and TV sets.
- Do not install the TV on furniture that can easily be used as steps, such as a chest of drawers.
- Care should be taken to install the TV where it cannot be pushed, pulled over, or knocked down.
- Care should be taken to route all AC power cords and connecting cables so that they cannot be pulled or grabbed by curious children.



Medical institutions

Do not place this TV in a place where medical equipment is in use. It may cause a medical equipment malfunction.



Outdoor use

Do not install this TV outdoors. The TV should not be exposed to rain or direct sunlight in order to avoid damage and possible fire or electric shock.

Do not install this TV in a vehicle, ship or other vessel

- Excessive bumping motion of a moving vehicle or continuous swaying motion on a boat may cause the TV to fall down and cause injury.
- Exposing the TV to seawater may cause a fire, electric shock or damage to your TV.

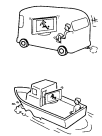











Magnetic influence

- This TV contains a strong magnet in the speaker unit that generates a magnetic field. Keep any items susceptible to magnetic fields away from the speaker.
- Electro-magnetic radiation emitted from optional equipment installed too close to the TV may cause picture distortion and/or noisy sound.

# Consignes de sécurité importantes





# Instrucciones importantes de seguridad





- Lisez les directives suivantes.
- Conservez ces directives.
- Observez et respectez tous les avertissements.
- Suivez toutes les directives.
- N'utilisez pas cet appareil près de l'eau. 
- Nettoyez cet appareil uniquement avec un chiffon sec. 
- Ne bouchez pas les fentes de ventilation. Respectez les directives du fabricant pour l'installation de l'appareil. 
- N'installez pas l'appareil à proximité d'une source de chaleur telle qu'un radiateur, une bouche d'air chaud, une cuisinière ou tout autre appareil (y compris des amplificateurs) émettant de la chaleur. 
- Ne désactivez pas le dispositif de sécurité appliqué à la fiche polarisée ou à la fiche avec mise à la terre. Une fiche polarisée est équipée de deux lames dont l'une est plus large que l'autre. Une fiche avec mise à la terre est équipée de deux lames et une broche destinée à la mise à la terre. La lame la plus large et la troisième broche sont des dispositifs de sécurité. Si vous ne réussissez pas à brancher la fiche fournie dans la prise de courant, consultez un électricien et faites remplacer la prise par une neuve. 

- Ne placez pas le cordon d'alimentation dans des endroits passants et assurez-vous qu'il ne peut pas être pincé, surtout au niveau des fiches, de la prise de courant et à l'endroit où il sort de l'appareil. 
- Utilisez uniquement les éléments de raccordement et les accessoires recommandés par le fabricant. 
- Utilisez l'appareil uniquement avec le chariot, le trépied, le support ou la table recommandés par le fabricant ou achetés avec l'appareil. Lorsque vous utilisez un chariot, prenez des précautions en déplaçant le chariot et l'appareil afin de ne pas les renverser, ce qui pourrait entraîner des blessures. 
- Débranchez cet appareil en cas d'orage ou lorsque vous ne l'utilisez pas pendant de longues périodes. 
- Pour toute réparation, adressez-vous à un réparateur qualifié. Faites réparer l'appareil s'il a été endommagé de quelque manière que ce soit, par exemple si le cordon d'alimentation ou sa fiche sont endommagés, si du liquide ou tout autre corps étranger a pénétré dans l'appareil, si l'appareil a été exposé à la pluie ou à l'humidité, s'il ne fonctionne pas normalement ou s'il est tombé. 

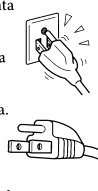
*Veillez respecter les consignes de sécurité supplémentaires pour éviter les risques d'électrocution, de court-circuit, d'incendie, de blessure et de dommages à la propriété.*

**Reportez-vous au verso pour plus d'information.**

- Lea estas instrucciones.
- Guarde estas instrucciones.
- Respete todas las advertencias.
- Siga todas las instrucciones.
- No utilice este aparato cerca del agua. 
- Límpielo únicamente con un paño seco. 
- No bloquee los orificios de ventilación. Instale el aparato según las instrucciones del fabricante. 
- No lo instale cerca de fuentes de calor como radiadores, calefactores, hornos u otros aparatos (incluidos los amplificadores) que generen calor. 
- Respete la finalidad de seguridad del enchufe polarizado o de tipo conexión a tierra. Un enchufe polarizado presenta dos contactos, uno más ancho que el otro. Un enchufe de tipo conexión a tierra dispone de dos contactos y una tercera clavija de conexión a tierra. El contacto ancho o la tercera clavija se suministra para su seguridad. Si el enchufe suministrado no encaja en la toma de corriente, póngase en contacto con un electricista para el reemplazo del tomacorriente que quedó obsoleto. 

- Para proteger el cable de alimentación, aléjelo de lugares de paso o donde pueda ser aplastado, especialmente en la punta de los enchufes, los tomacorrientes o el punto donde el cable sale del aparato. 
- Utilice únicamente los complementos o accesorios especificados por el fabricante. 
- Utilícelo únicamente con el carro, pedestal, trípode, abrazadera o mesa especificados por el fabricante o vendidos con el aparato. Si utiliza un carro, tenga cuidado al moverlo junto con el aparato para evitar lesiones en el caso de una caída. 
- Desenchufe el aparato durante tormentas eléctricas o cuando no se utilice durante periodos de tiempo prolongados. 
- Solicite servicio técnico únicamente a personal de servicio técnico especializado. Será necesario solicitar servicio técnico si el aparato ha sufrido daños como, por ejemplo, si el cable de alimentación o el enchufe están dañados, se ha vertido líquido o se ha caído algún objeto dentro del aparato, o bien si dicho aparato ha sido expuesto a la lluvia o a humedad, no funciona correctamente o se ha caído. 

*Tenga en cuenta las advertencias de seguridad adicionales para evitar descargas eléctricas, cortocircuitos, incendios, lesiones corporales o daños materiales.*

**Consulte el reverso para obtener más información.**

## onal Safety DOs and DON'Ts

### Wall-mount use

- Wall-mount installation requires the use of a Wall-mount Bracket. When installing or removing the TV and the Wall-Mount Bracket, be sure to use qualified contractors. If not properly secured during installation or removal from the Wall-Mount Bracket, the TV may fall and cause serious injury.
- Be sure to follow the installation guide supplied with the Wall-Mount Bracket when installing the TV.
- Be sure to attach the brackets with the specified parts supplied with the Wall-Mount Bracket.
- Do not hang the TV from the ceiling. It may fall and cause serious injury.
- Do not hang anything on the TV.
- Do not allow children to climb on the TV. 

### AC POWER CORD

- Do not touch the AC power cord and its plug with wet hands as it may cause electric shock.
- When disconnecting the AC power cord, grasp the plug and disconnect from the wall outlet first. Do not pull by the cord.
- Keep the power cord away from heat sources.
- A TV set with a three-wire grounding type AC power cord plug must be connected to an AC power outlet with a protective earthing connection.
- Do not convert or damage the AC power cord.
- Consult your electrician to have the outlet changed to suit your TV.

Subjecting the AC power cord to wear and/or abuse can damage the AC power cord and your TV.

- Do not place the TV where the power cord can be easily pinched, bent, twisted, or catch your feet. 

- Do not allow anything to rest on or roll over the cord.
- Before connecting cables, be sure to unplug the AC power cord for your safety. 

- Do not move the TV with the AC power cord (or other cables such as audio and video) connected.
- Use only an original Sony AC power cord with your TV; no brand substitution is allowed.
- Do not use AC power cord supplied with the TV with any other equipment.
- Never use a damaged AC power cord. A damaged AC power cord can cause a short-circuit, which may result in a fire or electric shock. 

Do not use a damaged or poorly fitting AC power outlet as your TV's power source.

- Insert the plug fully into the outlet. If it is loose, it may cause arcing and result in a fire.
- Do not overload the same AC power outlet. 

Unplugging the AC power cord from the wall outlet will completely remove power from the TV.

- During lightning storms or when the TV is left unattended and unused for extended periods of time, the AC power cord should be unplugged from the wall outlet. This will avoid possible damage to your TV. Also unplug the antenna to prevent damage to the TV. 
- For energy conservation and safety reasons, practice unplugging the AC power cord from the AC power outlet.

### Clean the AC power plug

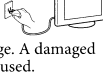
Unplug the AC power plug and clean it occasionally to avoid dust from accumulating. While cleaning, look for signs of damage. A damaged AC power cord should never be used. 

### ACCESSORIES

Keep small accessories out of children's reach. Use only the specified accessories with this TV.

### Volume Adjustment

- When using headphones, adjust the volume to avoid excessive audio levels from causing possible hearing loss. 

### BATTERIES

Your remote control batteries are consumables.

- To preserve our environment, dispose of used batteries according to your local laws or regulations.

- Do not dispose of batteries in a fire.
- Do not short-circuit, disassemble or overheat the batteries.
- Replace only with the same or equivalent type of batteries. Using incorrect replacement batteries can lead to an explosion.
- Do not place the remote in a location near a heat source, a place subject to direct sunlight, or a damp room.

### LCD SCREEN

Although the LCD screen is made with high-precision technology and has effective pixels of 99.99% or more, black dots or bright points of light (red, blue, or green) may appear constantly on the LCD screen. This is a structural property of the LCD panel and is not a malfunction.

- The LCD screen is made with high-precision technology and to achieve a high level of performance and picture quality, this TV's backlight setting is set to maximize the brightness of the TV. However, uneven brightness may be observed when the LCD TV is viewed in a dark ambient without an input source or with a blank screen. This condition is normal and not a malfunction of the TV. Changing the Picture mode, Backlight setting, enabling the Light Sensor (if applicable), or turning on the Power Management will improve this condition.

- To avoid damaging the LCD panel, do not expose the LCD screen to direct sunlight.
- Do not push or scratch the LCD screen, or place objects on top of the TV. The images may be uneven or the LCD panel may be damaged.
- If the TV is used in a cold place, the picture may smear or become dark. This does not indicate a failure. These phenomena improve as the temperature rises.
- Ghosting may occur when still pictures are displayed continuously. It should disappear after a few moments.
- The LCD screen and enclosure get warm when the TV is in use. This is not a malfunction.
- Avoid spraying insect repellent with volatile material on the LCD screen.

- Avoid prolonged contact with rubber or plastic material to the LCD screen.

### Broken screen panel

Do not throw anything at the TV as the impact can cause the LCD screen glass to crack, break or scatter. 

- If damage occurs to the LCD panel, small traces of liquid crystal sandwiched between the glass may be found on scattered broken glass.
- Do not touch the broken glass with bare hands. As with any broken glass pieces, avoid skin contact and exposure to your eyes or mouth. Avoid direct contact with liquid or damp surfaces of the glass as these may have an adverse effect on some people. The contacted area should be rinsed thoroughly with water. If conditions persist, see your doctor.
- If the surface of the TV cracks, do not touch the TV until you have unplugged the AC power cord. Otherwise electric shock may result.

### SERVICING

Do not use the TV if you suspect the TV is damaged or if the TV is damaged. 

- Do not attempt to service the TV yourself since opening the cabinet may expose you to dangerous voltage levels or other hazards. Refer all servicing to qualified service personnel.
- If replacement parts are required, acquire a written certification from the service technician which states that adequate replacement parts with the same or similar characteristics as the original parts have been used. Unauthorized substitutions may result in a fire, an electric shock or other hazards.

### Safety check

- Upon completion of any TV servicing or repair, ask the service technician to perform routine safety checks as specified by Sony and to certify that the TV is safe to operate. Have a qualified service technician dispose of the TV if it is not safe to operate. 

## AVERTISSEMENT

Afin de réduire les risques d'incendie et d'électrocution, n'exposez pas ce téléviseur à la pluie ou à l'humidité.

Le téléviseur ne doit jamais être exposé aux éclaboussures, au déversement ou à l'égouttement de liquides, quels qu'ils soient.



Ce sigle vise à signaler à l'utilisateur la présence d'une « tension dangereuse » non isolée au sein du téléviseur, dont la puissance peut être suffisante pour provoquer un risque d'électrocution.



Ce sigle vise à signaler à l'utilisateur la présence d'une documentation importante concernant les instructions de fonctionnement et d'entretien de ce téléviseur.

## Mise à la terre de l'antenne extérieure

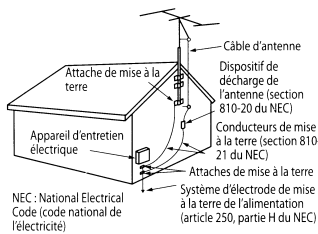

## ADVERTENCIA

Para reducir el riesgo de incendio o descarga eléctrica, no exponga este televisor a la humedad ni la lluvia.

El televisor no debe estar nunca expuesto a goteos, salpicaduras o derrames de ningún tipo de líquido.



Este símbolo pone sobre aviso al usuario de la presencia de « voltaje peligroso » sin aislamiento en el interior del televisor, el cual puede ser de tal intensidad que podría presentar riesgo de descarga eléctrica.



Este símbolo tiene por objeto advertir al usuario que la documentación que acompaña a este televisor contiene instrucciones importantes de operación y mantenimiento (servicio).

## Conexión a tierra de una antena exterior

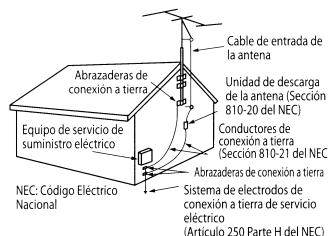

## HUMIDITÉ

- Ne placez pas d'objets contenant des liquides, tels qu'un vase ou une plante en pot, sur le téléviseur.
- N'utilisez pas un téléviseur alimenté par une source de courant électrique près de l'eau (baignoire, lavabo, évier de cuisine, cuve de lavage, piscine, sous-sol humide, etc.).



## NETTOYAGE

- Avant d'effectuer le nettoyage, veillez à débrancher le cordon d'alimentation pour éviter tout risque d'électrocution.
- Nettoyez le boîtier du téléviseur avec un chiffon sec et doux.
- Essayez délicatement l'écran ACL avec un chiffon doux.
- Enlevez les taches tenaces à l'aide d'un chiffon légèrement humidifié avec une solution de savon doux et d'eau tiède.
- Ne pulvérisez pas d'eau ou de détergent directement sur le téléviseur. Le liquide peut goutter jusqu'au bas de l'écran ou des pièces extérieures et provoquer un dysfonctionnement.
- Si vous utilisez un chiffon prétraité avec un produit chimique, suivez bien les directives indiquées sur l'emballage.
- N'utilisez jamais de solvants corrosifs tels qu'un diluant, de l'alcool ou du benzène pour nettoyer l'appareil.
- Il est recommandé de nettoyer périodiquement les ouvertures de ventilation avec un aspirateur afin de garantir une bonne ventilation.



## VENTILATION

- Les ouvertures de ventilation du téléviseur sont nécessaires pour assurer le bon fonctionnement du téléviseur et le protéger de la surchauffe.
- Ne bloquez pas et ne couvrez pas les ouvertures de ventilation avec du tissu ou d'autres matériaux.
- Ne placez jamais le téléviseur sur un lit, un canapé, un tapis ou toute autre surface similaire qui pourrait bloquer les ouvertures de ventilation.
- Sans une ventilation correcte, de la poussière peut s'accumuler dans le téléviseur et provoquer des dommages.
- Ne laissez jamais tomber de liquides ou d'objets dans les ouvertures de ventilation.



- Si un objet ou du liquide tombe à l'intérieur du téléviseur, débranchez-le immédiatement et faites-le vérifier par un technicien qualifié avant de le faire fonctionner de nouveau.
- N'introduisez jamais d'objet quel qu'il soit dans le téléviseur par les fentes du boîtier, car il pourrait toucher des points de haute tension ou court-circuiter des pièces et provoquer un incendie ou l'électrocution.

Laissez un espace suffisant autour du téléviseur pour assurer une circulation d'air adéquate.

- N'installez jamais le téléviseur dans un espace restreint, comme une bibliothèque ou un meuble encastré, à moins que la ventilation nécessaire ne soit prévue.
- Laissez un espace libre d'au moins 30 cm (11 7/8 po) au-dessus du téléviseur et de 10 cm (4 po) de chaque côté. Si vous installez l'appareil au mur, laissez un espace libre d'au moins 10 cm (4 po) en dessous de l'écran. (Reportez-vous au mode d'emploi pour des renseignements supplémentaires.)



## INSTALLATION

Installez le téléviseur près d'une prise de courant CA facilement accessible.

- N'installez pas le téléviseur avec l'écran vers le haut ou vers le bas, ni à l'envers ou sur le côté.
- N'installez pas le téléviseur dans des endroits chauds, humides ou excessivement poussiéreux.
- N'installez pas le téléviseur dans des endroits sujets à des extrêmes de température, par exemple à la lumière directe du soleil ou encore près d'un radiateur ou d'une bouche de chaleur. Dans de telles conditions, le téléviseur pourrait surchauffer, ce qui peut provoquer une déformation du boîtier et/ou des problèmes de fonctionnement.
- N'installez pas le téléviseur dans un endroit exposé directement à l'air climatisé; de l'humidité pourrait se condenser à l'intérieur du téléviseur et provoquer des problèmes de fonctionnement.
- N'installez pas le téléviseur dans un endroit où il peut être exposé à des vibrations mécaniques.
- N'installez pas le téléviseur dans un endroit où peuvent pénétrer les insectes.
- N'installez pas le téléviseur dans un endroit où il dépasserait, par exemple sur ou derrière une colonne, ou dans un endroit où vous pourriez le heurter de la tête et vous blesser.
- Pour éviter les risques d'incendie, tenez les objets inflammables et la flamme nue (p. ex. les bougies) à distance du téléviseur.
- Ne posez aucun appareil sur le téléviseur.



## Consigne:

### Prévenez le basculement du téléviseur

- Prenez les mesures nécessaires afin d'éviter que le téléviseur ne bascule, ce qui pourrait provoquer des blessures ou des dommages au téléviseur ou à d'autres objets.
- Fixez le téléviseur à un mur ou à un support.
- N'installez jamais le téléviseur sur une surface inégale et/ou instable.
- Ne laissez pas les enfants jouer avec le meuble ou le téléviseur et ne les laissez pas grimper dessus.
- N'installez pas le téléviseur sur un meuble qui peut facilement être escadé, par exemple une commode à tiroirs.
- Veillez à installer le téléviseur dans un endroit où il ne risque pas d'être poussé, tiré ou renversé.
- Veillez à acheminer tous les cordons d'alimentation CA et câbles de raccordement de manière à ce qu'ils soient hors de la portée des enfants, qui pourraient les manipuler ou les tirer par curiosité.



### Établissements médicaux

N'installez pas ce téléviseur dans un endroit où des appareils médicaux sont utilisés. Il pourrait entraîner des problèmes de fonctionnement des appareils médicaux.



### Utilisation à l'extérieur

N'installez pas ce téléviseur à l'extérieur. N'exposez pas le téléviseur à la pluie ou à la lumière directe du soleil pour éviter de l'endommager et de provoquer des risques d'incendie ou d'électrocution.

### N'installez pas ce téléviseur dans un véhicule ou sur un bateau ou autre embarcation

- Les sursauts excessifs d'un véhicule en mouvement ou le mouvement de balancier répété d'un bateau peuvent faire tomber le téléviseur et entraîner des blessures.
- L'exposition du téléviseur à l'eau de mer peut poser un risque d'incendie ou causer des dommages au téléviseur.

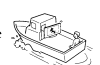

### Champ magnétique

- Les haut-parleurs de ce téléviseur contiennent un aimant puissant générant un champ magnétique. Veillez à tenir tout objet sensible aux champs magnétiques à distance des haut-parleurs.
- L'installation d'appareils externes à trop grande proximité du téléviseur peut provoquer une distorsion de l'image ou des parasites sonores, en raison des radiations électromagnétiques.

## Prácticas de seguridad

### HUMEDAD

- No coloque objetos con líquidos, como floreros o macetas con plantas, sobre el televisor.
- No utilice un televisor que requiera alimentación eléctrica cerca del agua como, por ejemplo, cerca de bañeras, lavamanos, fregaderos o piletas de lavado, en un sótano húmedo ni cerca de una piscina.



### LIMPIEZA

- Durante la limpieza, asegúrese de desenchufar el cable de alimentación para evitar la posibilidad de una descarga eléctrica.
- Limpie el mueble del televisor con un paño seco y suave.
- Limpie la pantalla LCD con cuidado con un paño suave.
- Las manchas difíciles pueden limpiarse con un paño ligeramente humedecido con una solución de jabón suave y agua tibia.
- No rocíe agua ni detergente directamente sobre el televisor. Podría gotear a la parte inferior de la pantalla o partes exteriores, y ocasionar un mal funcionamiento.
- Si utiliza un paño tratado químicamente, siga las instrucciones que se indican en el paquete.
- Nunca limpie el televisor con disolventes fuertes como diluyentes, alcohol o bencina.
- Se recomienda retirar el polvo con una aspiradora de las aberturas de ventilación de forma periódica para garantizar una buena ventilación.



### VENTILACIÓN

Las aberturas de ventilación del televisor son necesarias para asegurar una operación fiable del televisor y protegerlo contra el sobrecalentamiento.

- No bloquee o cubra las aberturas de ventilación con paños ni otros materiales.
- Nunca coloque el televisor sobre una cama, sofá, alfombra u otras superficies similares que puedan obstruir las aberturas de ventilación.
- Si el televisor no cuenta con una ventilación adecuada, puede acumular polvo y dañarse.
- No permita que caigan líquidos u objetos sólidos dentro de las aberturas de ventilación.

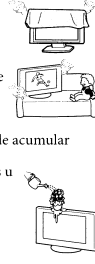

- Si caen líquidos u objetos sólidos dentro del televisor, desenchufe el televisor inmediatamente y haga que verifique su funcionamiento un técnico de reparación calificado antes de seguir operándolo.
- Nunca introduzca objetos de ningún tipo en las ranuras del mueble, ya que podrían entrar en contacto con puntos de voltaje peligrosos o causar cortocircuitos, lo cual podría ocasionar un incendio o una descarga eléctrica.

Deje suficiente espacio alrededor del televisor para garantizar una buena circulación del aire.

- Nunca coloque el televisor en un lugar cerrado, como en un librero o un mueble empotrado, a menos que haya ventilación adecuada.
- Se debe dejar como mínimo un espacio de 30 cm encima del televisor y 10 cm a cada lado. Si se monta en la pared, deje como mínimo un espacio de 10 cm debajo de la pantalla. (Consulte la información adicional que se suministra en el Manual de instrucciones.)



### INSTALACIÓN

- Se recomienda instalar el televisor cerca de un tomacorriente de ca de fácil acceso.
- No instale el televisor boca arriba, boca abajo, ni lo apoye sobre un lateral.
- No instale el televisor en lugares cálidos, grasientos, húmedos o expuestos a temperaturas excesivas de polvo.
- No instale el televisor en lugares sometidos a temperaturas extremas, como por ejemplo los expuestos a la luz solar directa, los cercanos a un radiador o a un conducto de calefacción. El televisor podría calentarse en tales condiciones y producir la deformación del interior del aparato y/o empezar a funcionar defectuosamente.
- No instale el televisor en un lugar expuesto de forma directa al aire acondicionado; se podría condensar la humedad en su interior y empezar a funcionar defectuosamente.
- No instale el televisor en lugares expuestos a vibraciones mecánicas.
- No instale el televisor en lugares que puedan atraer insectos.
- No instale el televisor en un lugar donde pudiera sobresalir, como encima o detrás de una columna, o donde pudiera golpearlo con la cabeza o producir lesiones corporales.
- Para evitar incendios, mantenga los objetos inflamables y llamas (por ejemplo, velas) alejados del televisor.
- No coloque ningún equipo opcional sobre el televisor.



### Medidas para evitar que se vuelque el televisor

- Tome las medidas adecuadas para evitar que el televisor se vuelque y provoque lesiones, que se dañe el televisor o que se produzcan daños materiales.
- Fije el televisor a la pared o a una base de soporte.
- No instale nunca el televisor sobre superficies inestables y/o desniveladas.
- No permita que los niños se suban a los muebles y al televisor o que jueguen con éstos.
- No instale el televisor sobre muebles que se puedan utilizar fácilmente como escaleras, como una cómoda.
- Procure instalar el televisor donde no se pueda empujar, hacer a un lado o derribar.
- Procure enrutar todos los cables de alimentación de ca y los cables de conexión de manera que no puedan tirar de ellos ni agarrarlos niños curiosos.



### Centros médicos

No coloque el televisor en un lugar donde se utilicen equipos médicos, puesto que podría interferir con el funcionamiento de equipo médico.



### Uso del televisor en un lugar exterior

No instale este televisor en un lugar al aire libre. No se debe exponer el televisor a la lluvia o a la luz solar directa para evitar daños y la posibilidad de un incendio o una descarga eléctrica.

### No instale este televisor en vehículos, barcos o buques

- El movimiento excesivo del vehículo o el balanceo continuo de un barco pueden provocar la caída del televisor y causar lesiones.
- Si lo expone al agua del mar, puede provocar un incendio, una descarga eléctrica o causar daños internos.



### Campos magnéticos

- En las bocinas de este televisor se encuentra un fuerte imán que genera un campo magnético. Mantenga alejado de las bocinas del televisor cualquier elemento susceptible de daños producidos por campos magnéticos.
- La radiación electromagnética emitida desde el equipo opcional instalado demasiado cerca del televisor puede distorsionar la imagen y/o producir ruido.

### Montaje en pared

- La instalación en una pared requiere un soporte de montaje en pared. Cuando instale o quite el televisor y el soporte de montaje en pared, asegúrese de hacerlo con contratistas calificados. Si no se fija adecuadamente durante la instalación o desinstalación del soporte de montaje en pared, el televisor podría caerse y causar lesiones graves.



# as de sécurité supplémentaires

## Installation au mur

- L'installation au mur nécessite l'utilisation d'un support de fixation murale. Pour l'installation ou le démontage du téléviseur et du support de fixation murale, faites appel à un entrepreneur qualifié. Si le téléviseur est mal fixé pendant l'installation ou le retrait du support de fixation murale, il peut tomber et causer des blessures graves.
- Suivez bien le guide d'installation fourni avec le support de fixation murale lors de l'installation du téléviseur.
- Veillez à fixer les supports avec les pièces indiquées fournies avec le support de fixation murale.
- Ne suspendez pas le téléviseur au plafond. Il pourrait tomber et provoquer des blessures graves.
- N'accrochez aucun objet au téléviseur.
- Ne laissez pas les enfants monter sur le téléviseur.



## CORDON D'ALIMENTATION CA

- Ne touchez pas le cordon d'alimentation CA ou la fiche avec des mains humides, ce qui pourrait provoquer l'électrocution.
  - Pour débrancher le cordon d'alimentation CA, saisissez d'abord la fiche et débranchez-la de la prise murale. Ne tirez pas sur le cordon lui-même.
  - Maintenez le cordon d'alimentation à l'abri des sources de chaleur.
- Un téléviseur doté d'un cordon d'alimentation CA avec une fiche à trois broches avec mise à la terre doit être branché dans une prise de courant CA comportant une protection de mise à la terre.
- Ne modifiez pas et n'endommagez pas le cordon d'alimentation CA.
  - Faites changer toute prise défectueuse par votre électricien afin de pouvoir y brancher votre téléviseur.



Fait de soumettre le cordon d'alimentation à une usure prématurée et/ou à un mauvais traitement peut entraîner des dommages au cordon d'alimentation CA et au téléviseur.

- N'installez pas le téléviseur à un endroit où le cordon d'alimentation peut être facilement pincé, plié ou tordu, ou faire trébucher quelqu'un.



- Ne laissez rien reposer ou rouler sur le cordon.
- Pour votre sécurité, débranchez le cordon d'alimentation CA avant de brancher les câbles.
- Ne déplacez pas le téléviseur lorsque le cordon d'alimentation CA est branché, ni lorsque d'autres câbles (audio ou vidéo, par exemple) sont raccordés.

- Utilisez uniquement un cordon d'alimentation CA Sony d'origine pour votre téléviseur; aucune autre marque ne convient.
- N'utilisez pas le cordon d'alimentation CA fourni avec le téléviseur sur un autre appareil.
- N'utilisez jamais un cordon d'alimentation CA endommagé. Un cordon d'alimentation CA endommagé peut provoquer un court-circuit, ce qui peut causer un incendie ou l'électrocution.



Ne branchez pas votre téléviseur dans une prise de courant endommagée ou dans laquelle la fiche ne s'insère pas bien.



- Insérez la fiche complètement dans la prise. Un branchement lâche peut entraîner un arc électrique et un incendie.
- Ne surchargez pas la prise de courant CA.



Pour interrompre complètement l'alimentation électrique du téléviseur, débranchez le cordon d'alimentation CA de la prise de courant.

- Pendant les orages et lorsque vous n'utilisez pas le téléviseur pendant une longue période, débranchez le cordon d'alimentation CA de la prise de courant. Cette mesure vise à éviter des dommages potentiels à votre téléviseur. Débranchez également l'antenne pour éviter les dommages au téléviseur.
- Pour des raisons de sécurité et pour économiser l'électricité, exercez-vous à débrancher le cordon d'alimentation CA de la prise de courant CA.



## Nettoyez la fiche du cordon d'alimentation CA

Débranchez la fiche du cordon d'alimentation CA et nettoyez-la de temps à autre pour éviter l'accumulation de poussière. Pendant le nettoyage, vérifiez que le cordon est en bon état. N'utilisez jamais un cordon d'alimentation CA endommagé.



## ACCESSOIRES

Gardez les petits accessoires hors de la portée des enfants. N'utilisez que les accessoires indiqués par le fabricant avec ce téléviseur.

## Réglage du volume

- Si vous utilisez des écouteurs, ne réglez pas le son à un volume excessif afin d'éviter d'endommager votre ouïe.



## PILES

- Les piles de la télécommande sont des produits consommables.
- Pour protéger l'environnement, mettez au rebut les piles usées conformément aux lois et règlements locaux.
- Ne jetez pas les piles au feu.
- Ne court-circuitez pas les piles, ne les démontez pas et ne les faites pas surchauffer.
- Remplacez-les uniquement par des piles identiques ou de type équivalent. L'utilisation de piles de recharge incorrectes peut provoquer une explosion.
- Ne placez pas la télécommande à proximité d'une source de chaleur, dans un endroit exposé aux rayons directs du soleil ou dans une pièce humide.

## ÉCRAN ACL

- Bien que l'écran ACL soit le fruit d'une technologie de haute précision et que 99,99% ou plus de ses pixels soient efficaces, des points noirs ou des points lumineux (rouges, bleus ou verts) peuvent apparaître en permanence à l'écran ACL. Ceci est une propriété structurelle du panneau ACL et ne constitue pas un problème de fonctionnement.
- L'écran ACL de ce téléviseur a été conçu à partir de technologies de haute précision, et afin d'obtenir le meilleur rendement et la meilleure qualité d'image possible, le rétroéclairage du téléviseur est réglé pour en maximiser la luminosité. Toutefois, il est possible que vous observiez des zones moins claires que d'autres lorsque vous regardez un téléviseur ACL dans une pièce sombre alors que rien n'est affiché à l'écran. Il s'agit d'un phénomène normal et non d'un défaut de l'appareil. Le réglage des fonctions Mode image et Rétroéclairage, ou encore l'activation du Capteur de lumière (si applicable) ou de la fonction de gestion de l'alimentation vous permettent de régler l'écran afin d'améliorer cet aspect.
- Afin d'éviter d'endommager le panneau ACL, n'exposez pas l'écran ACL à la lumière directe du soleil.
- N'appuyez pas sur l'écran ACL, ne l'égratignez pas et ne placez pas d'objets sur le téléviseur. Cela pourrait provoquer l'instabilité de l'image ou des dommages au panneau ACL.
- Si le téléviseur est utilisé dans un environnement froid, l'image peut apparaître sale ou sombre. Ceci n'est pas le signe d'un problème de fonctionnement. Ce phénomène disparaît au fur et à mesure que la température augmente.
- Une image fantôme peut apparaître lorsque des images fixes sont affichées en continu. Elle devrait disparaître après quelques instants.
- L'écran ACL et le boîtier deviennent chauds lorsque le téléviseur est en cours d'utilisation. Il ne s'agit pas d'un problème de fonctionnement.

- Évitez de vaporiser sur l'écran ACL tout répulsif insecticide contenant des produits volatils.
- Évitez le contact prolongé de l'écran ACL avec le caoutchouc et les matériaux plastiques.

## Écran endommagé

- Ne jetez rien en direction de l'écran, car l'impact pourrait provoquer la fissuration, le bris ou l'éclatement du verre de l'écran ACL.
- Si le panneau ACL venait à être endommagé, des traces de cristaux liquides peuvent se retrouver entre deux épaisseurs de verre, parmi les morceaux de verre brisé.
- Ne touchez pas le verre brisé à mains nues. Comme dans toute situation de bris de verre, évitez le contact avec la peau et tenez les morceaux de verre à l'écart des yeux et de la bouche. Évitez le contact direct avec le liquide répandu et les morceaux de verre humides, car ces produits peuvent avoir un effet néfaste pour certaines personnes. En cas de contact, rincez la zone affectée abondamment à l'eau courante. Si des symptômes apparaissent, consultez votre médecin.
- Si la surface du téléviseur se fissure, ne touchez pas le téléviseur avant d'avoir débranché le cordon d'alimentation CA. Sinon, vous pourriez vous électrocuter.



## RÉPARATION

- N'utilisez pas le téléviseur si vous constatez ou croyez qu'il est endommagé.
- Ne tentez pas de réparer le téléviseur vous-même, car l'ouverture du boîtier pourrait vous exposer à des zones de tension élevée et à d'autres dangers. Pour toute réparation, adressez-vous à un technicien qualifié.
- Si des pièces doivent être remplacées, demandez au technicien de certifier par écrit que les pièces de rechange adéquates ont été utilisées et que leurs caractéristiques sont similaires ou identiques à celles des pièces d'origine. Toute substitution non autorisée pourrait causer un incendie, l'électrocution ou d'autres dangers.



## Révision de sécurité

- Après toute réparation ou tout entretien du téléviseur, demandez au technicien d'effectuer une vérification de routine, telle que spécifiée par Sony, et de certifier que le téléviseur fonctionne en toute sécurité. Si le téléviseur ne peut pas être utilisé de façon sécuritaire, confiez sa mise au rebut à un technicien qualifié.



# idad correctas e incorrectas adicionales

- Asegúrese de seguir la guía de instalación suministrada con el soporte de montaje en pared cuando instale el televisor.
- Asegúrese de fijar las abrazaderas con las piezas especificadas suministradas con el soporte de montaje en pared.
- No cuelgue el televisor del techo. Podría caerse y causar lesiones graves.
- No cuelgue ningún objeto en el televisor.
- No permita que los niños se suban al televisor.



## CABLE DE ALIMENTACIÓN DE CA

- No toque el cable de alimentación de ca ni el enchufe con las manos mojadas, ya que puede provocar una descarga eléctrica.
  - Cuando vaya a desconectar el cable de alimentación de ca, jale del enchufe y desconéctelo del tomacorriente de pared primero. No jale del cable.
  - Mantenga el cable de alimentación alejado de fuentes de calor.
- Un televisor debe conectarse con un enchufe de cable de alimentación de ca de tres terminales y toma a tierra a un tomacorriente de ca con una conexión a tierra de protección.
- No modifique ni dañe el cable de alimentación de ca.
  - Póngase en contacto con su electricista para adaptar el tomacorriente a su televisor.



Si el cable de alimentación de ca queda expuesto a desgaste y/o maltrato, se puede dañar el cable de alimentación de ca y el televisor.

- No coloque el televisor donde el cable de alimentación se pueda apretar, doblar o torcer fácilmente, o donde pueda atrapar los pies de una persona.



- No permita que ningún objeto se encuentre o pase sobre el cable.
- Antes de conectar los cables, desenchufe el cable de alimentación de ca para su seguridad.
- No mueva el televisor con el cable de alimentación de ca, ni con otros cables de audio y video, conectados.
- No utilice cables de alimentación de ca que no sean originales de la marca Sony.
- No utilice el cable de alimentación de ca suministrado con el televisor con ningún otro aparato.

- Nunca utilice un cable de alimentación de ca dañado. Un cable de alimentación de ca dañado puede provocar un cortocircuito, lo que puede producir un incendio o una descarga eléctrica.



No utilice un tomacorriente de ca dañado o mal instalado como la fuente de alimentación del televisor.



- Inserte el enchufe en el tomacorriente hasta que quede bien metido. Si el enchufe no encaja completamente, pueden producirse chispas que acaben provocando un incendio.
- No sobrecargue el mismo tomacorriente de ca.



Si se desenchufa el cable de alimentación de ca del tomacorriente de pared se corta el suministro eléctrico al televisor.

- Durante tormentas eléctricas o cuando no se utilice el televisor durante periodos de tiempo prolongados, se debe desenchufar el cable de alimentación de ca del tomacorriente de pared. Esto evitará la posibilidad de que se dañe su televisor. Desenchufe también la antena para evitar que se dañe el televisor.
- Para conservar energía y por motivos de seguridad, acostúmbrase a desenchufar el cable de alimentación de ca del tomacorriente de ca.



## Limpieza del enchufe del cable de alimentación de ca

Desenchufe el cable de alimentación de ca y límpielo de vez en cuando para evitar que se acumule el polvo. Durante la limpieza, compruebe la existencia de signos de daños. Nunca se debe utilizar un cable de alimentación de ca dañado.



## ACCESORIOS

Mantenga los pequeños accesorios alejados del alcance de los niños. Utilice únicamente los accesorios especificados para este televisor.

## Ajuste de volumen

- Cuando utilice audífonos, ajuste el volumen de forma que se eviten niveles excesivos de audio para no dañar los oídos.



## PILAS

- Las pilas del control remoto son consumibles.
- Para conservar el medio ambiente, siga las leyes o regulaciones locales para desechar las pilas usadas.
- No se deshaga de las pilas arrojándolas al fuego.



- No provoque un cortocircuito, desmonte ni recalcite las pilas.
- Reemplácelas sólo con el mismo tipo o uno equivalente. La utilización de pilas de repuesto incorrectas puede producir una explosión.
- No ponga el mando a distancia en un lugar cerca una fuente de calor, un lugar expuesto a la luz solar directa, ni en una habitación húmeda.

## PANTALLA LCD (CRISTAL LÍQUIDO)

- La pantalla LCD está fabricada con tecnología de alta precisión y dispone de un mínimo de 99,99% de píxeles efectivos. En esta pantalla aparecen constantemente puntos negros o puntos luminosos en rojo, azul o verde. No se trata de una falla de funcionamiento, sino de una característica estructural del panel LCD.
- La pantalla de cristal líquido (LCD) está fabricada con tecnología de alta precisión y para alcanzar un alto nivel de rendimiento y de calidad de imagen, esta configuración de retroiluminación se ajusta para maximizar el brillo del televisor. Sin embargo, es posible que se observe un brillo desigual cuando el televisor de pantalla de cristal líquido se ve en un ambiente oscuro sin una fuente de entrada o una pantalla en blanco. Esta condición es normal y no se trata de una falla de funcionamiento del televisor. Al cambiar el modo de Imagen, la configuración de Retroiluminación, al habilitar el Detector de luz (si aplicable) o al activar el Control de energía mejorará esta condición.
- Para evitar dañar el panel LCD, no exponga la pantalla LCD a la luz solar directa.
- No presione ni raye la pantalla LCD, ni coloque objetos sobre el televisor. Es posible que las imágenes resulten irregulares o que se dañe el panel LCD.
- Si se utiliza el televisor en un lugar frío, es posible que la imagen se oscurezca o que aparezca una mancha en la pantalla. No se trata de una falla de funcionamiento. Estos fenómenos desaparecerán a medida que aumente la temperatura.
- Si se ven imágenes fijas continuamente, puede que se produzca un efecto de imagen fantasma. Esto debería desaparecer transcurridos unos segundos.
- Cuando se utiliza el televisor, la pantalla LCD y la caja se calientan. No se trata de una falla de funcionamiento.
- No use repelentes insecticidas en aerosol con material volátil sobre la pantalla LCD.
- Evite el contacto prolongado de la pantalla LCD con material de goma o plástico.

## Panel de pantalla rojo

No arroje ningún objeto contra el televisor pues el impacto puede hacer que el cristal de la pantalla LCD se rajе, se rompa o se dispersе.



- Si se daña el panel LCD, es posible que se encuentren pequeños rastros de cristal líquido metidos entre el cristal en los fragmentos de cristal esparcidos.
- No toque el cristal roto con las manos. Como con cualquier trozo de cristal roto, evite el contacto con la piel, los ojos o la boca. Evite el contacto directo del cristal con líquidos o superficies húmedas pues éstos pueden tener un efecto perjudicial sobre algunas personas. Enjuague la zona de contacto con agua abundante. Si los síntomas persisten, acuda a un médico.
- Si la superficie del televisor se rompe, desenchufe el cable de alimentación de ca antes de tocar el televisor. De lo contrario, podría producirse una descarga eléctrica.

## REPARACIÓN

- No utilice el televisor si sospecha que está dañado o si el televisor está dañado.
- No intente reparar usted mismo el televisor, ya que al abrirlo se vería expuesto a voltajes peligrosos y otros riesgos. Solicite servicio técnico únicamente a personal calificado.
- Cuando sean necesarias piezas de repuesto, solicite al técnico de reparación que certifique por escrito haber utilizado piezas de repuesto adecuadas con las mismas características que las originales o con características similares. La utilización de piezas no autorizadas podría causar incendios, descargas eléctricas u otros peligros.



## Comprobación de seguridad

- Después de haber finalizado cualquier servicio de mantenimiento o reparación del televisor, solicite al técnico de reparación que realice y certifique las comprobaciones de seguridad rutinarias según lo especificado por Sony para determinar si el televisor se encuentra en condiciones seguras de operación. Solicite a un técnico de reparación calificado que se deshaga del televisor si no se encuentra en condiciones seguras de operación.





PS3  
PlayStation 3



PlayStation®Network

Experience the next level of gaming and entertainment with Sony advanced Stereoscopic 3D technology and the PlayStation®3.



**3D**  
world

Created by Sony

Introducing the best way to experience movies, sports and games from the leaders in advanced Stereoscopic 3D technology<sup>1</sup>. To become a part of the action visit [sony.com/3DWorld](http://sony.com/3DWorld)

<sup>1</sup> 3D viewing requires a 3D HDTV or a 3D Ready HDTV plus Sony 3D Sync Transmitter, 3D content, a 3D capable player (if 3D content is on disc), a high speed HDMI™ (supporting at least 10.2 Gbps) and 3D glasses (all sold separately).

**SONY**  
make.believe



Download these Free Stereoscopic 3D Games and Demos from the PlayStation®Network

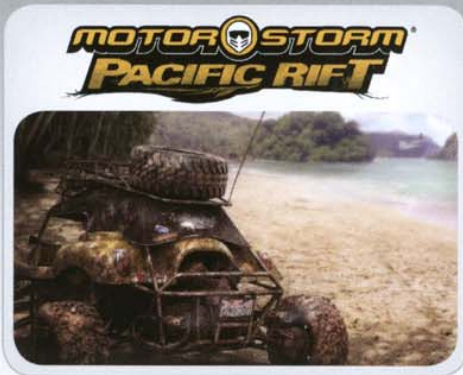

Demo available in full advanced Stereoscopic 3D technology



Download includes a portion of the full game. Specific Game Modes support advanced Stereoscopic 3D technology



Full game in advanced Stereoscopic 3D technology



Full game in advanced Stereoscopic 3D technology



Use this voucher code to download all four games and demos from the PlayStation®Network



Scratch off above for Promotion Code. Valid June 10, 2010 – March 31, 2011.\*

Instructions for redeeming a Promotion Code on your PS3™ system:

- Step 1:** Open an account on the PlayStation®Network (or use an existing account).
- Step 2:** From the PlayStation®Network icon on the Xross Media Bar, select 'Account Management.'
- Step 3:** Select 'Redeem Codes.'
- Step 4:** Enter Promotion Code. Please note that the Promotion Code is case sensitive and must be entered exactly as displayed.

Once the Promotion Code has been entered correctly, click 'Continue.' Once you accept the terms, you will be taken to the download screen.

Downloadable games only available to legal U.S. and Canadian residents with a PlayStation®Network ("PSN") account who are 13 or older and have a valid PlayStation®Network account. The promotion code ("Code") is good for one qualifying PSN account to redeem the entitlement to download offered downloaded games for the PlayStation®3 computer entertainment system via the PlayStation®Store. Code expires 3/31/2011. Once code is redeemed, however, the entitlement permits download of these offered downloaded games to five (5) PS3 activated systems even after Code expiration. The approximate value of the Code is \$0.00 USD. Code is not redeemable for cash, cannot be returned for cash or credit, may not be used for any other purpose and will not be replaced if lost, stolen, or damaged.

For assistance, go to [www.us.playstation.com/support](http://www.us.playstation.com/support) or contact SCE Consumer Services at 1-800-345-7669.

\*Start date and terms subject to change without notice.

Use of the PlayStation®Network is subject to the PlayStation Network Terms of Service and User License Agreement and applicable privacy policy, see [www.us.playstation.com/support/useragreements](http://www.us.playstation.com/support/useragreements). Children under 18 must have parental consent to establish a PlayStation Network Account and may not be able to access certain content or services. Broadband service required for download; user responsible for associated fees. PlayStation Network features and offerings may change without notice.

MotorStorm is a registered trademark of Sony Computer Entertainment Europe. © 2007 Sony Computer Entertainment Europe. Developed by Evolution Studios Ltd. PAIN © 2007-2009 Sony Computer Entertainment America LLC. Super Stardust™ HD © 2007 Sony Computer Entertainment Europe. Developed by Housemarque OY. Super Stardust is a trademark of Sony Computer Entertainment Europe. wipEout® HD © 2008 Sony Computer Entertainment Europe. WipEout is a registered trademark of Sony Computer Entertainment Europe. "PlayStation" and the "PS" Family logo are registered trademarks and "PS3" and the PlayStation Network logo are trademarks of Sony Computer Entertainment Inc. Player responsible for Wi-Fi fees. All games featured are trademarked and copyrighted properties of their respective publishers and/or licensors.

Cover: © 2010 Sony Electronics Inc. All rights reserved. Reproduction in whole or in part without written permission is prohibited. The Sony, make.believe and BRAVIA logos are trademarks of Sony. All other trademarks are trademarks of their respective owners.

PS3

EXTRA LINE  
BD  
DVDs  
IT  
ONLY  
DOES  
EVERYTHING.™

3D GAMES  
3D MOVIES  
BLU-RAY

INTERNET BROW  
WI-FI

TROPHY  
BUILT-IN HA  
7.1 SOUND  
THEMES  
PLAYSTATION  
FILTER



**Experience the Best Stereoscopic 3D Games  
and Movies Only On PlayStation®3.**

Enjoy the only gaming system that delivers incredible high-definition Stereoscopic 3D games and movies with the built-in Blu-ray Disc player. Plus, PS3 has Wi-Fi for multi-player online gaming, Internet browsing, and downloading games, movies, and TV shows through the PlayStation®Network.

[www.us.playstation.com/ps3](http://www.us.playstation.com/ps3)



PS3

PlayStation®3



PlayStation®Network



# Get the most out of your Sony HDTV with DIRECTV.

Special offer for Sony customers—  
Get **Free HD** from DIRECTV.



**A great deal to get the most from your Sony HDTV.  
GET FREE HD ACCESS FOR 12 MONTHS!**  
A \$120 savings on top of DIRECTV's nationally advertised offer.

With activation of CHOICE™ Package or above along with HD Access.\* Conditions apply.  
SEE INSIDE FOR OFFER DETAILS.

PACKAGES STARTING AT

**\$29<sup>99</sup>**  
mo.

Everyday Low Price

CALL TODAY!

**1-877-214-0245**

**SONY**



# Give your Sony HDTV the HD performance it needs.

## DIRECTV DELIVERS WHAT THE COMPETITION CAN'T.

THE MOST HD CHANNELS.  
PERIOD.

# 130+ HD CHANNELS

All in HD, all the time.<sup>3</sup>

Cable isn't close—  
on average 1/2  
the HD channels.<sup>4</sup>

DISH Network counts 25  
"part-time" HD channels.

### MORE REASONS TO SWITCH TO DIRECTV

- 1** #1 rated customer satisfaction 4 years running.<sup>2</sup>
- 2** The channels you love: AMC, Bravo, MSNBC, FX and 38 others DISH Network doesn't offer in their basic package.<sup>5</sup>
- 3** Industry leading DVR technology—with twice the storage capacity of cable.<sup>6</sup>
- 4** Exclusive sports packages that you can't get on cable or DISH Network.

#### LOCAL CHANNELS IN HD



Eligibility for local channels based on service address. Not all networks available in HD in all markets.

#### 15 PREMIUM MOVIE CHANNELS IN HD



Available by subscription.

#### HD CHANNELS

HD Access required (\$10/mo.)



## DIRECTV. THE UNDISPUTED LEADER IN SPORTS



### NBA LEAGUE PASS

Get your ticket to the most NBA action with up to 40 regular season games a week from outside your local area.



### MLB EXTRA INNINGS®

Keep on top of America's pastime with the ultimate baseball package—MLB EXTRA INNINGS.® You'll see up to 80 out-of-market games a week featuring your favorite teams, players and matchups.



### NHL® CENTER ICE®

Follow your favorite NHL teams throughout the season with NHL® CENTER ICE.® Up to 40 exciting games a week and up to 20 games a week in HD.



### NFL SUNDAY TICKET™

Sunday means up to 14 heart-stopping, bone-rattling games. Problem is, cable and DISH Network offer just 4. So get every game, every Sunday, with NFL SUNDAY TICKET™—and follow your favorite team no matter where you live.

Professional and collegiate sports subscriptions sold separately. Actual number of games varies by market due to blackout restrictions and other conditions.

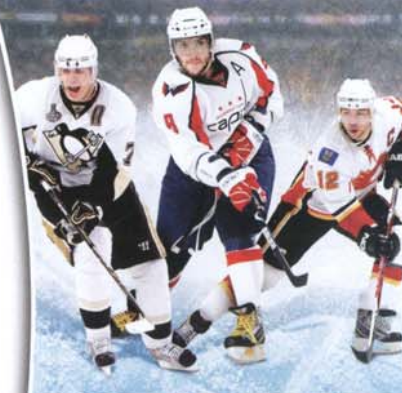

NHL® CENTER ICE®



NFL SUNDAY TICKET™

# FREE

Professional Installation



Lease fee of \$5/mo. for second and each additional receiver. Complex/Custom installation extra. \$19.95 handling and delivery fee may apply.

# FREE HD

Access for 12 months with the CHOICE™ Package or above.

With activation of CHOICE™ Package or above, along with HD Access.<sup>1</sup>

PACKAGES STARTING AT

# \$29<sup>99</sup> mo.

Everyday Low Price

Get the most from your Sony HDTV with DIRECTV.  
Order DIRECTV® service now!  
**CALL 1-877-214-0245**

SONY



Offers end 3/31/11. New approved customers only. Credit card required. Must maintain programming, DVR and/or HD Access. Hardware lease required and available separately. Applicable use tax adjustment may apply on the retail value of the installation. See back for details.

# Hook up your Sony HDTV with FREE HD from DIRECTV!

Get the most from your Sony HDTV with DIRECTV.  
**GET FREE HD ACCESS FOR 12 MONTHS!**

A \$120 savings on top of DIRECTV's nationally advertised offer.

With activation of CHOICE™ Package or above, along with HD Access.† See inside for details.

## Every DIRECTV package includes:

- NO Equipment to Buy
- 99.9% Worry-Free Signal Reliability
- #1 in Customer Satisfaction<sup>2</sup>
- Local Channels Included<sup>1</sup>



Independent channels.  
In select markets.

To get the most from your new Sony HDTV, order DIRECTV now.

# CALL 1-877-214-0245

SONY



Credit card not required in MA & PA. <sup>1</sup>Local channel eligibility based on service address. <sup>2</sup>Customer satisfaction measured among the largest national cable & satellite TV providers. Tied with DISH Network in 2007, 2006-2009 American Satisfaction Index. <sup>3</sup>Number of HD channels varies based on package. To access DIRECTV HD programming, HD Access (\$10 mo.) and HD equipment are required. <sup>4</sup>Based on average number of HD channels offered by cable providers in major metropolitan areas. Actual number of HD channels varies provider and market. <sup>5</sup>Comparison based on DIRECTV CHOICE Package vs. DISH Network's America's Top 120 packages. <sup>6</sup>Based on the largest national cable providers' HD DVRs versus DIRECTV's HD DVR (model HR22 or later). Actual recording capacity depends on type of programming being recorded. **FREE HD ACCESS FOR 12 MONTHS:** Activation of a DIRECTV HD Receiver or HD DVR with CHOICE Package or above along with HD Access fee required. **INSTALLATION:** Standard professional installation only. Custom installation extra. **SYSTEM LEASE:** Purchase of 24 consecutive months of any DIRECTV base programming package (\$29.99/mo. or above) or qualifying international services bundle required. **FAILURE TO ACTIVATE IN ACCORDANCE WITH THE EQUIPMENT LEASE ADDENDUM MAY RESULT IN A CHARGE OF \$150 PER RECEIVER. IF SERVICE IS TERMINATED BEFORE THE END OF AGREEMENT, A CANCELLATION FEE OF \$20/MONTH REMAINING WILL APPLY. ALL EQUIPMENT IS LEASED AND MUST BE RETURNED TO DIRECTV UPON CANCELLATION, OR UNRETURNED EQUIPMENT FEES APPLY. VISIT [directv.com](http://directv.com) OR CALL 1-800-DIRECTV FOR DETAILS.** Programming, pricing, terms and conditions subject to change at any time. Pricing residential. Taxes not included. Receipt of DIRECTV programming subject to DIRECTV Customer Agreement; copy provided at [directv.com/legal](http://directv.com/legal) and in first bill. ©2010 DIRECTV, Inc. DIRECTV, the Cyclone Design logo and CHOICE are trademarks of DIRECTV, Inc. All other trademarks and service marks are the property of their respective owners.

4-198-223-01(1)



4198223011

Printed in U.S.A.

**SONY**  
make.believe

Register your new BRAVIA® HDTV with 3D  
and get 2 Blu-ray 3D™ movies on us.

Act Now  
on this  
Exclusive  
Sony Offer



*Cloudy With A Chance of Meatballs on Blu-ray 3D™. Screen image simulated.*

Get 2 Blu-ray 3D movies by mail when you purchase and  
register your BRAVIA 3D capable HDTV.  
Go to **[www.sony.com/3Dregistration](http://www.sony.com/3Dregistration)** to register today.



For questions regarding this promotion or to check the status of your movie delivery please call  
1-866-838-0421 or visit [www.rebate-zone.com/sony](http://www.rebate-zone.com/sony)

Receive two Blu-ray 3D movies (Deep Sea by IMAX and Warner Bros. Entertainment & Cloudy with a Chance of Meatballs from Sony Pictures Home Entertainment) by mail following the purchase and online registration of an eligible 3D or 3D Ready Sony BRAVIA HDTV. Eligible models: XBR-60LX900, XBR-52LX900, XBR-52HX909, XBR-46HX909, KDL-55HX800, KDL-46HX800, KDL-40HX800, KDL-60NX810, KDL-55NX810, KDL-46NX810, KDL-46NX711 and KDL-40NX711. Offer valid on purchase of eligible product between June 10, 2010 and September 30, 2010. Eligible product must be registered online at [www.sony.com/3Dregistration](http://www.sony.com/3Dregistration) by October 31, 2010. Online registration must include: name, mailing address (no PO Boxes), e-mail address, product/model number, purchase date and place of purchase. Blu-ray 3D movies will be mailed to the address provided when registering the eligible 3D or 3D Ready Sony BRAVIA HDTV. For movie delivery, please allow 8-10 weeks following registration of eligible product. Limit one redemption of this offer per household, except where prohibited by law. Limited to end users only (not for resale). Delivery to P.O. Boxes is not accepted. Offer is not transferable. Sony reserves the right to request additional information to validate a claim, making it subject to U.S. postal regulations. Offer void where prohibited, taxed or restricted by law. Registration information becomes Sony property. Products for which this offer is claimed may not be returned; this return restriction does not apply to warranty claims. Sony reserves the right to substitute products of greater or equal value or cash equivalent in fulfillment of this offer. Offer valid only in the United States, excluding territories. Offer not valid on refurbished, open-box, returned products, or demonstration products. Sony reserves the right to modify or cancel this offer at any time.

© 2010 Sony Electronics Inc. All rights reserved. Reproduction in whole or in part without written permission is prohibited. The Sony, make.believe and BRAVIA logos are trademarks of Sony. All other trademarks are trademarks of their respective owners. © 2009 Sony Pictures Animation Inc. All Rights Reserved.



## **END USER LICENSE AGREEMENT FOR CERTAIN SOFTWARE AND SERVICE TO BE USED WITH YOUR SONY PRODUCT**

### **IMPORTANT – READ THIS AGREEMENT BEFORE USING YOUR SONY PRODUCT. USING YOUR PRODUCT INDICATES YOUR ACCEPTANCE OF THIS AGREEMENT.**

This End User License Agreement (“EULA”) is a legal agreement between you and Sony Electronics Inc. (“Sony”), the licensor of the software (other than the software which is governed by other licenses as indicated below, the “Excluded Software”) included in this Sony Product and related materials which shall be collectively referred to as the “Sony Software.” This EULA covers the Sony Software and that of Sony’s third party licensors (“Third Party Licensors”) and accompanying printed or online documentation. The Sony Software includes software in your Sony Product, other software, including updates or modified software, provided to you by Sony, whether stored on media or downloaded to the Sony Product via any method.

This Sony Product also includes the BRAVIA® Internet Video feature which provides access to selected content services (“Services”) from third party content providers including Sony entities other than Sony Electronics Inc. (“Third Party Providers”) as a courtesy to you. The BRAVIA® Internet Video feature also provides you access to selected Sony content services (“Sony Content Services”), which services and related content (“Sony Content”) shall both be considered Sony Software under this EULA. The BRAVIA® Internet Video feature requires an Internet connection. Your ability to access the Services, and the quality of the Services presented, are subject to your Internet provider’s service and terms as well as the broadband Internet connection speed you use. Your ability to access the Services, and the quality of the Services presented, are

subject to your Internet provider’s service and terms. Video quality and picture size varies and is dependent upon the speed of your broadband service from your Internet provider and delivery by the Third Party Providers. The content, including but not limited to data, music, sound, audio, photographs, images, graphics, likenesses, software, text, video, messages, tags, or other materials, provided by Third Party Providers (“Content”) and the availability of the Services are at the sole discretion and under the control of the Third Party Providers. The Content and Services of each Third Party Provider are provided pursuant to the terms and conditions of that Third Party Provider. Premium Content may require additional fees and/or registration with the Third Party Provider through a computer. The Services and the Content may only be used for your own personal, private viewing, and shall not be used for non-theatrical exhibition, or any viewing or exhibition for which (or in a venue in which) an admission, access, or viewing fee is charged, or for any public exhibition or viewing. The Services may be changed at any time and may be unavailable from time to time.

**THE SONY SOFTWARE AND THE SERVICES MAY ALLOW SONY, THE THIRD PARTY PROVIDERS, AND/OR OTHER THIRD PARTIES TO COLLECT DATA FROM, CONTROL, AND/OR MONITOR THE SONY PRODUCT AND OTHER DEVICES RUNNING OR INTERACTING WITH THE SONY SOFTWARE. YOU HEREBY CONSENT TO SUCH ACTIVITIES. YOU ALSO AGREE TO SONY’S CURRENT PRIVACY POLICY THAT IS AVAILABLE AT [HTTP://PRODUCTS.SEL.SONY.COM/SEL/LEGAL/PRIVACY.HTML](http://products.sel.sony.com/sel/legal/privacy.html). SUCH PRIVACY POLICY MAY CHANGE FROM TIME TO TIME; PLEASE CONSULT THE**

**ABOVEMENTIONED LINK FOR ANY UPDATES TO THE POLICY. PLEASE CONTACT APPLICABLE THIRD PARTY PROVIDERS OR OTHER THIRD PARTIES FOR PRIVACY POLICIES RELATED TO THEIR SERVICES. BY USING YOUR SONY PRODUCT, YOU AGREE TO BE BOUND BY THE TERMS OF THIS EULA AND SONY'S PRIVACY POLICY.**

If you do not agree to the terms of this EULA or Sony's privacy policy, as amended from time to time by Sony in its discretion, Sony is unwilling to license the Sony Software to you and unwilling to allow you to access the Services, and you should promptly contact Sony for instructions on the return of the entire Sony Product and included Sony Software for a refund of the purchase price of the Sony Product.

**SOFTWARE LICENSE**

You cannot use the Sony Software except as specified herein. The Sony Software is licensed, not sold. Sony and its Third Party Licensors grant you a limited license to use the Sony Software only on the Sony Product. The Sony Software may create data files automatically for use with the Sony Software, and you agree that any such data files are deemed to be a part of the Sony Software. The Sony Software is licensed as a single product, and you may not separate its component parts for use on more than one device unless expressly authorized by Sony. You agree not to modify, reverse engineer, decompile or disassemble the Sony Software in whole or in part or to use the Sony Software in whole or in part for any purpose other than allowed under this EULA. In addition, you may not rent, lease, sublicense, or sell the Sony Software, but you may transfer all of your rights under this EULA only as part of a sale or transfer of the Sony Product provided you retain no copies, transfer all of the Sony Software (including all copies, component parts, any media, printed materials, all versions and any upgrades of the Sony Software, and this EULA), and the recipient agrees to the terms of this EULA. Sony and its Third Party Licensors retain all rights that this EULA does not expressly grant

to you. You shall not (a) bypass, modify, defeat, or circumvent any of the functions or protections of the Sony Software or any mechanisms operatively linked to the Sony Software; or (b) remove, alter, cover, or deface any trademarks or notices on the Sony Software. You understand, acknowledge, and agree that the software, network services, or other products other than the Sony Software upon which the Sony Software's performance may depend might be interrupted or discontinued at the discretion of the suppliers (software suppliers, service providers, Third Party Providers, etc.) or Sony.

**USER ACCOUNT**

As part of the agreement to allow you to access, browse, or use the Services and the Content, Third Party Providers and/or other third parties may require that you establish a user account ("Account") for which you must provide them with true, accurate, current, and complete information about yourself and maintain/promptly update such information. You are responsible for maintaining the confidentiality of any and all of your passwords associated with any such Account.

**SONY'S RIGHTS TO USER'S MATERIAL**

If you send any communications or materials to Sony by electronic mail or otherwise ("Materials"), including any selections, comments, data, questions, suggestions, or the like, all such Materials are, and will be treated as, non-confidential and non-proprietary. Thus, you give up any claim that use of such Materials violates any of your rights including moral rights, privacy rights, proprietary or other property rights, rights of publicity, rights to credit for material or ideas, or any other right, including the right to approve the way Sony uses such Materials. Any Material may be adapted, broadcast, changed, copied, disclosed, licensed, performed, posted, published, sold, transmitted, or used by Sony anywhere in the world, in any medium, forever and without attribution or compensation to you. Furthermore, you hereby assign all right, title, and interest

in, and Sony is free to use, without any compensation to you, any ideas, know-how, concepts, techniques, or other intellectual property rights contained in the Materials, whether or not patentable, for any purpose whatsoever, including but not limited to developing, manufacturing, having manufactured, licensing, marketing, and selling products using such Materials. However, you agree and understand that Sony is not obligated to use any such ideas, know-how, concepts, or techniques or Materials, and you have no right to compel such use.

**TRANSMITTED MATERIAL**

Internet transmissions are never completely private or secure. You understand that any message or information you send to Sony may be read or intercepted by others, unless there is a special notice that a particular message (for example, credit card information) is encrypted (sent in code). Sending a message to Sony does not cause Sony to have any special responsibility to you.

**DIGITAL RIGHTS MANAGEMENT**

Content owners use Windows Media digital rights management technology ("WMDRM") to protect their intellectual property, including copyrights. This Sony Product uses WMDRM software to access WMDRM-protected Content. If the WMDRM software fails to protect the Content, Content owners may ask Microsoft Corporation ("Microsoft") to revoke the Service's ability to use WMDRM to play or copy protected Content. Revocation does not affect unprotected Content. If you download licenses for protected Content, you agree that Microsoft may include a revocation list with the licenses. Content owners may require you to upgrade WMDRM to access their Content. If you decline an upgrade, you will not be able to access Content that requires the upgrade.

**ADVERTISEMENTS, SERVICE COMMUNICATIONS**

Inclusion of the Service of a Third Party Provider does not mean that Sony approves of, or endorses, or recommends

that Third Party Provider or its Content. You understand and agree that the Services and/or Content may include advertisements ("Advertisements"), and that these Advertisements are necessary in order for the Services to be provided. You also understand and agree that the use of the BRAVIA® Internet Video feature may include certain communications from Sony or Third Party Providers such as service announcements, administrative messages, newsletters, and the like ("Service Communications"), and that you will not be able to opt out of receiving such Service Communications. SONY, ITS AFFILIATES, AND ITS THIRD PARTY PROVIDERS DISCLAIM ALL WARRANTIES, EXPRESS OR IMPLIED, AS TO THE ACCURACY, LEGALITY, RELIABILITY, OR VALIDITY OF ANY ADVERTISEMENT, SERVICE COMMUNICATIONS, OR CONTENT, AS WELL AS ANY LIABILITY ARISING UNDER ANY THEORY OF LAW FOR THE ADVERTISEMENTS, SERVICE COMMUNICATIONS, AND CONTENT.

**OBJECTIONABLE CONTENT AND RULES FOR MINORS (UNDER AGE 16)**

Certain Content may not be suitable for minors or other users. Such Content may or may not be rated or identified as having explicit language, or otherwise being for a mature audience. Therefore, you acknowledge that you are using the Services at your own risk and that Sony has no liability to you for the Content, including any Content that may be offensive. You are responsible for supervising the use of the Sony Product, the Sony Software, Excluded Software, the Services, and the Content by any minor. If you are under the age of 16, you should ask your parent(s) or a guardian before you: (i) e-mail Sony via the Service; (ii) send in any information; (iii) enter any contest or game that requires information about you or offers a prize; (iv) join any club or group; (v) post any information on any bulletin board or enter any chatroom; or (vi) buy anything online.

**EXCLUSION OF WARRANTY**

YOU UNDERSTAND, ACKNOWLEDGE, AND AGREE THAT THE CONTENT AND SERVICES ARE PROVIDED BY THIRD PARTY PROVIDERS AND/OR SOFTWARE IS PROVIDED BY THIRD PARTIES OVER WHICH SONY HAS NO CONTROL. THE SELECTION, PROVISION, QUALITY, PICTURE SIZE, AND AVAILABILITY OF SUCH CONTENT AND/OR SOFTWARE ARE THE SOLE RESPONSIBILITY OF SUCH THIRD PARTY PROVIDER OR OTHER THIRD PARTY. YOU AGREE TO COMPLY WITH ANY AND ALL TERMS AND CONDITIONS THAT THE THIRD PARTY PROVIDERS MAY SET FOR ITS SERVICE, CONTENT AND/OR SOFTWARE. YOU FURTHER UNDERSTAND, ACKNOWLEDGE, AND AGREE THAT ACCESS, BROWSING, AND USAGE OF THE SERVICES REQUIRES INTERNET SERVICE PROVIDED BY YOU, AND FOR WHICH YOU ARE SOLELY RESPONSIBLE, INCLUDING BUT NOT LIMITED TO THE PAYMENT OF ANY THIRD PARTY FEES (SUCH AS INTERNET SERVICE PROVIDER OR AIRTIME CHARGES) FOR SUCH ACCESS AND FOR DISPLAY OR DELIVERY OF ADVERTISEMENTS INCLUDED WITH THE SERVICES. OPERATION OF THE BRAVIA® INTERNET VIDEO FEATURE AND THE SERVICE MAY BE LIMITED OR RESTRICTED DEPENDING ON THE CAPABILITIES, BANDWIDTH OR TECHNICAL LIMITATIONS OF YOUR INTERNET SERVICE. SONY, ITS AFFILIATES, AND ITS THIRD PARTY PROVIDERS SHALL HAVE NO RESPONSIBILITY FOR THE TIMELINESS, DELETION, MIS-DELIVERY, OR FAILURE TO STORE ANY USER COMMUNICATIONS OR PERSONALIZED SETTINGS.

THE SONY SOFTWARE AND ACCOMPANYING DOCUMENTATION, THE SERVICES, AND THE CONTENT ARE FURNISHED TO YOU "AS IS" AND WITHOUT WARRANTIES OR CONDITIONS, STATUTORY OR OTHERWISE, OF ANY KIND. SONY, ITS AFFILIATES, ITS THIRD PARTY LICENSORS, AND ITS THIRD PARTY PROVIDERS EXPRESSLY DISCLAIM ALL WARRANTIES AND CONDITIONS,

EXPRESS OR IMPLIED, INCLUDING BUT NOT LIMITED TO THE IMPLIED WARRANTIES OF NON-INFRINGEMENT, TITLE, MERCHANTABILITY, AND FITNESS FOR A PARTICULAR PURPOSE. SONY, ITS AFFILIATES, ITS THIRD PARTY LICENSORS, AND ITS THIRD PARTY PROVIDERS DO NOT WARRANT THAT THE SONY SOFTWARE OR ACCOMPANYING DOCUMENTATION, THE SERVICES, OR THE CONTENT WILL MEET YOUR REQUIREMENTS OR THAT THE OPERATION OF THE SONY SOFTWARE, THE SERVICES, OR THE CONTENT WILL BE UNINTERRUPTED OR ERROR FREE. FURTHERMORE, SONY, ITS AFFILIATES, ITS THIRD PARTY LICENSORS, AND ITS THIRD PARTY PROVIDERS DO NOT WARRANT OR MAKE ANY REPRESENTATIONS OR CONDITIONS REGARDING THE USE OR THE RESULTS OF THE USE OF THE SONY SOFTWARE, THE SERVICES OR THE CONTENT IN TERMS OF ITS CORRECTNESS, ACCURACY, RELIABILITY OR OTHERWISE. NO ORAL OR WRITTEN INFORMATION OR ADVICE GIVEN BY SONY, ITS AFFILIATES, OR A SONY AUTHORIZED REPRESENTATIVE SHALL CREATE A WARRANTY OR CONDITION, OR IN ANY WAY CHANGE THIS EXCLUSION OF WARRANTY AND CONDITION. SHOULD THE SOFTWARE, MEDIA ON WHICH THE SOFTWARE IS FURNISHED, DOCUMENTATION, THE SERVICES, OR THE CONTENT PROVE DEFECTIVE, YOU (AND NOT SONY OR A SONY AUTHORIZED REPRESENTATIVE) ASSUME THE ENTIRE COST OF ALL NECESSARY SERVICING, REPAIR, OR CORRECTION.

**LIMITATION OF LIABILITY**

IN NO EVENT WILL SONY (INCLUDING BUT NOT LIMITED TO ANY NEGLIGENCE ISSUES RELATED TO THIRD PARTY LICENSORS OR THIRD PARTY PROVIDERS), ITS AFFILIATES, ITS THIRD PARTY LICENSORS OR ITS THIRD PARTY PROVIDERS BE LIABLE TO YOU FOR ANY SPECIAL, INDIRECT, INCIDENTAL, PUNITIVE, EXEMPLARY, OR CONSEQUENTIAL DAMAGES OF ANY KIND, INCLUDING BUT NOT LIMITED

TO COMPENSATION, REIMBURSEMENT OR DAMAGES IN CONNECTION WITH, ARISING OUT OF OR RELATING TO THIS EULA, ON ACCOUNT OF THE LOSS OF USE OF THE SONY PRODUCT, DOCUMENTATION, THE SERVICES, THE CONTENT, DOWN TIME AND YOUR TIME, LOSS OF PRESENT OR PROSPECTIVE PROFITS, LOSS OF DATA, INFORMATION OF ANY KIND, BUSINESS PROFITS, OR OTHER COMMERCIAL LOSS, OR FOR ANY OTHER REASON WHATSOEVER, EVEN IF SONY, ITS AFFILIATES, ITS THIRD PARTY LICENSORS, OR ITS THIRD PARTY PROVIDERS HAVE BEEN ADVISED OF THE POSSIBILITY OF SUCH DAMAGES. THE SONY SOFTWARE AND ACCOMPANYING DOCUMENTATION, THE SERVICES, AND THE CONTENT ARE FURNISHED TO YOU FOR USE AT YOUR OWN RISK. SONY, ITS AFFILIATES, ITS THIRD PARTY LICENSORS, AND ITS THIRD PARTY PROVIDERS WILL NOT BE LIABLE FOR DAMAGES FOR BREACH OF ANY EXPRESS OR IMPLIED WARRANTY OR CONDITION, BREACH OF CONTRACT, NEGLIGENCE, STRICT LIABILITY OR ANY OTHER LEGAL THEORY RELATED TO THE SONY SOFTWARE, THE SERVICES, THE CONTENT, OR THIS EULA.

Some jurisdictions may not allow exclusions or limitations of incidental or consequential damages, exclusions or limitations of implied warranties or conditions, or allow limitations on how long an implied warranty lasts, so the above limitations or exclusions may not apply to you.

**LIMITED WARRANTY ON MEDIA**

In situations where the Sony Software or any part thereof is furnished on media, Sony warrants that for a period of ninety (90) days from the date of its delivery to you, the media on which the Sony Software is furnished to you will be free from defects in materials and workmanship under normal use. This limited warranty extends only to you as the original licensee. Sony's entire liability and your exclusive remedy will be replacement of the media not meeting Sony's limited warranty. ANY IMPLIED WARRANTIES

OR CONDITIONS ON THE MEDIA, INCLUDING THE IMPLIED WARRANTIES AND CONDITIONS OF MERCHANTABILITY, TITLE, NON-INFRINGEMENT, AND/OR FITNESS FOR A PARTICULAR PURPOSE, ARE LIMITED IN DURATION TO NINETY (90) DAYS FROM THE DATE OF DELIVERY. SOME JURISDICTIONS DO NOT ALLOW LIMITATIONS ON HOW LONG AN IMPLIED WARRANTY OR CONDITION LASTS, SO THESE LIMITATIONS MAY NOT APPLY TO YOU. THIS WARRANTY GIVES YOU SPECIFIC LEGAL RIGHTS, AND YOU MAY ALSO HAVE OTHER RIGHTS WHICH VARY FROM JURISDICTION TO JURISDICTION.

**FEES**

Sony and its Third Party Providers reserve the right at any time to charge fees for access to new Content or new Services or to portions of the existing Content or Services, or the Services as a whole. In addition, Third Party Providers may charge fees for access to their Content. In no event will you be charged for access to any portion or all of the Content and/or the Services unless Sony and/or a Third Party Provider obtain your prior agreement to pay such charges. If you do not consent to such charges, however, you may not have access to paid Content or Services for which such charges apply.

**INTELLECTUAL PROPERTY / NOTICE FOR CLAIMS OF INTELLECTUAL PROPERTY VIOLATIONS AND AGENT FOR NOTICE**

Sony respects the intellectual property rights of others, and we ask you to do the same. It is Sony's policy, at its discretion as appropriate, (a) to terminate and/or disable the Content of Third Party Providers or users of the Services who may infringe or repeatedly infringe the copyrights or other intellectual property rights of Sony, its Third Party Providers or others; and/or (b) to forward reports of intellectual property rights violations to Third Party Providers and others for review and action per the terms of such Third Party Provider's procedures for protection of intellectual property rights. The Sony Software and Content are protected by copyright laws and international copyright treaties, as well

as other intellectual property laws and treaties. There may be proprietary logos, service marks, trademarks, likenesses, and trade names found in the Sony Software, the Content, or on the Services. By making the Sony Software and Content available on the Services, Sony and the Third Party Providers are not granting you any license to utilize those proprietary logos, service marks, trademarks, likenesses, or trade names. Any unauthorized use of the Sony Software, the Services, or the Content may violate copyright laws, trademark laws, the laws of privacy and publicity, and civil and criminal statutes. All right, title, and interest in and to the Sony Software and the Content, and any and all copies or portions thereof, are owned by Sony, its licensors, Third Party Licensors, suppliers and/or Third Party Providers. All rights not specifically granted under this EULA are reserved by Sony, its licensors, Third Party Licensors, suppliers and/or Third Party Providers.

You are responsible for all your activities hereunder, including all legal liability incurred from access, browsing, or use of the Services by you or by others who use the Services via your Sony Product or Account (as defined in the User Account section). You may use the Sony Software, the Services, and the Content for lawful purposes only. You may not distribute, exchange, modify, sell, or transmit anything you may copy from the Sony Software, the Services, or the Content, including but not limited to any data, text, software, likenesses, photographs, images, graphics, audio, music, sound, video, messages, and tags, for any business, commercial, or public purpose. As long as you comply with the terms of this EULA, Sony grants you a nonexclusive, nontransferable, limited right to use the BRAVIA® Internet Video feature to access the Services and the Content as set forth in this EULA. You further agree not to interrupt/disrupt or attempt to interrupt/disrupt the operation of the Sony Software, the Service or the Content in any way.

If you believe your work has been copied in a way that constitutes copyright infringement, or that your intellectual property rights have otherwise been violated, please first contact the Third Party Provider for the particular Service. If you are unable to contact such Third Party Provider, or the content at issue is Sony's, you may contact Sony's Intellectual Property Agent (listed below) with the following information in a written notice: (a) an electronic or physical signature of the person authorized to act on behalf of the copyright or other intellectual property interest; (b) a description of the copyrighted work or other intellectual property that you claim has been infringed; (c) a description of the particular Service and where the material that you claim is infringing is located on such Service, with enough detail that we may find the material; (d) your address, telephone number, and e-mail address; (e) a statement by you that you have a good faith belief that the disputed use is not authorized by the copyright or intellectual property owner, its agent, or the law; and (f) a statement by you, made under penalty of perjury, that the above information in your notice is accurate and that you are the copyright or intellectual property owner or authorized to act on the copyright or intellectual property owner's behalf. Sony's agent for notice of copyright or other intellectual property right infringement is as follows: Intellectual Property Agent, c/o Sony Electronics Inc., 16530 Via Esprillo, San Diego, CA 92127; Facsimile (858) 942-9123; E-Mail IPagent@am.sony.com

#### **INDEMNIFICATION**

You agree to indemnify, defend, and hold harmless Sony and all of its agents, directors, officers, employees, information providers, licensors and licensees, affiliates, content providers, and direct and indirect parent(s) (collectively, "Indemnified Parties") from and against any and all liability and costs (including, without limitation, attorneys' fees and costs) incurred by the Indemnified Parties in connection with any claim arising

out of (i) any breach or alleged breach by you of this EULA in any manner, (ii) any information you submit to Sony hereunder, (iii) any breach or alleged breach by you of a third party's rights, (iv) any damage caused by or alleged to have been caused by you to the Sony Software, the Services, or the Content. Counsel you select for defense or settlement of a claim must be consented to by Sony and/or Indemnified Party(s) prior to counsel being engaged to represent you and Sony and/or Indemnified Party(s). You and your counsel will cooperate as fully as reasonably required by the Indemnified Party(s) in defense or settlement of any claim. Sony and/or Indemnified Party(s) reserve the right, at its own expense, to assume the exclusive defense or settlement, and control of any matter otherwise subject to indemnification by you. You shall not in any event consent to any judgment, settlement, attachment, or lien, or any other act adverse to the interest of Sony or any Indemnified Party without the prior written consent of Sony and/or Indemnified Party(s).

#### **AUTOMATIC UPDATE FEATURE / MODIFICATION OF EULA AS TO SERVICES**

From time to time, Sony or third parties may automatically update or otherwise modify the Sony Software, for example, but not limited to, for purposes of error correction, improvement of features, and enhancement of security features. Such updates or modifications may change or delete the nature of features or other aspects of the Sony Software, including features you may rely upon. You hereby agree that such activities may occur at Sony's sole discretion and that Sony may condition continued use of the Sony Software upon your complete installation or acceptance of such update or modifications. Sony may add to, change, or remove any part, term, or condition of the EULA as it applies to the Sony Software, the Services, and/or the Content at any time without prior notice to you. Any such additions, changes, or removals or any terms posted in the

BRAVIA® Internet Video feature shall apply as soon as they are posted. By continuing to access the Services, the Sony Content Services, the Content, and/or the Sony Content after so posted, you are indicating your acceptance thereto. SONY MAY ADD, CHANGE, DISCONTINUE, REMOVE, OR SUSPEND ANY OF THE SERVICES OR THE SONY CONTENT SERVICES, TEMPORARILY OR PERMANENTLY, AT ANY TIME, WITHOUT NOTICE AND WITHOUT LIABILITY. WITHOUT PREJUDICE TO ANY OTHER RIGHTS, SONY MAY SUSPEND OR TERMINATE THIS EULA AS TO THE SERVICES, THE SONY CONTENT SERVICES, THE CONTENT, AND/OR THE SONY CONTENT IMMEDIATELY UPON NOTICE IF YOU FAIL TO COMPLY WITH THE TERMS AND CONDITIONS OF THIS EULA. Sony may take any legal and technical remedies to prevent violation of and/or to enforce this EULA, including, without limitation, immediate termination of your access to the Services, if Sony believes in its discretion that you are violating this EULA.

#### **HIGH RISK ACTIVITIES**

The Sony Software is not fault-tolerant and is not designed, manufactured or intended for use or resale as on-line control equipment in hazardous environments requiring fail-safe performance, such as in the operation of nuclear facilities, aircraft navigation or communication systems, air traffic control, direct life support machines, or weapons systems, in which the failure of the Sony Software could lead to death, personal injury, or severe physical or environmental damage ("High Risk Activities"). SONY, EACH OF THE THIRD PARTY LICENSORS, AND EACH OF THEIR RESPECTIVE AFFILIATES SPECIFICALLY DISCLAIM ANY EXPRESS OR IMPLIED WARRANTY OR CONDITION OF FITNESS FOR HIGH RISK ACTIVITIES.

#### **RESTRICTIONS ON EXPORT OF ENCRYPTION TECHNOLOGY**

The Sony Software and the Content may contain encryption technology. You acknowledge that any export of Sony Software or the Content containing encryption technology from the United

States or subsequent re-export of such software by a person located outside of the United States requires a license or other authorization from the U.S. Department of Commerce's Bureau of Industry and Security. You further acknowledge that the Sony Software or the Content containing encryption technology and acquired from Sony is not intended for use by a foreign government end user. By accepting this license agreement, you agree to abide by all relevant U.S. export laws and regulations in the purchase and use of the Sony product being acquired, including but not limited to those regulations relating to the export control of cryptographic items and not to transfer, or authorize the transfer, of the Sony Software or the Content to a prohibited country or otherwise in violation of any such restrictions or regulations.

#### **US GOVERNMENT RESTRICTED RIGHTS**

The Sony Software is provided with RESTRICTED RIGHTS. Use, duplication or disclosure by the United States Government is subject to restrictions as set forth in subparagraphs (c)(1) and (c)(2) of the Commercial Computer Software clause at FAR 52.227 19, and subparagraph (c)(i)(ii) of the Rights in Technical Data and Computer Software clause at DOD FAR 252.227-7013 and any comparable federal, state or local law or regulation. Manufacturer is Sony Electronics Inc., 16530 Via Esprillo, San Diego, CA 92127.

#### **JURY TRIAL WAIVER**

THE PARTIES HERETO WAIVE TRIAL BY JURY WITH RESPECT TO ANY MATTERS ARISING UNDER OR RELATING TO THIS EULA. Any cause of action you may have with respect to the Services must be commenced within one (1) year after the claim or cause of action arises.

#### **ENTIRE AGREEMENT, NOTICE, WAIVER, SEVERABILITY**

This EULA, the limited warranty accompanying the Sony Product, Sony's then-current privacy policy, and any additional terms and conditions posted on the Services, together constitute the entire agreement between you and Sony with

respect to the Sony Product, the Sony Software, the Services, and the Content. Any notice by Sony hereunder may be made by letter, e-mail, or posting on the Services. The failure of Sony to exercise or enforce any right or provision of this EULA shall not constitute a waiver of such right or provision. If any part of this EULA is held invalid, illegal, or unenforceable, that provision shall be enforced to the maximum extent permissible so as to maintain the intent of this EULA, and the other parts will remain in full force and effect.

#### **THIRD PARTY BENEFICIARIES**

Each Third Party Licensor and each Third Party Provider is an express intended third-party beneficiary of, and shall have the right to enforce, each provision of this EULA with respect to the software, service, and content, as applicable, of such party.

#### **EXCLUDED SOFTWARE**

Excluded Software included in the Sony Product is not subject to this EULA. Please refer to the section of this booklet entitled "NOTICES AND LICENSES FOR SOFTWARE USED IN THIS PRODUCT" for a list of the applicable software and terms and conditions governing the use of such Excluded Software.

#### **TERM**

This EULA is effective until terminated. Sony may terminate this EULA immediately if you fail to comply with its terms by giving you notice. In such event, you must destroy the Sony Software and accompanying documentation, and all copies you have made of them. In addition, upon termination you will have no recourse against Sony, its affiliates, its Third Party Licensees, or its Third Party Providers for your inability to use the Sony Software or the accompanying documentation, the Services, or the Content.

Should you have any questions concerning this EULA, you may contact Sony by writing to Sony Electronics Inc. 16530 Via Esprillo, San Diego, California 92127 U.S.A.

## **NOTICES AND LICENSES FOR SOFTWARE USED IN THIS PRODUCT**

#### **GPL/LGPL LICENSED SOFTWARE**

The following GPL executables and LGPL libraries are used in this product and are subject to the GPL/LGPL License Agreements included as part of this documentation:

#### **Package list:**

linux-kernel  
busybox  
pump-autoip  
libjs  
dosfstools  
directfb  
iptables  
cairo  
glib  
pango  
exceptionmonitor

Source code for these executables and libraries, as well as other executables and libraries, can be obtained using the following link:

<http://www.sony.net/Products/Linux/>

#### **GNU GENERAL PUBLIC LICENSE**

**Version 2, June 1991**

Copyright (C) 1989, 1991 Free Software Foundation, Inc., 51 Franklin Street, Fifth Floor, Boston, MA 02110-1301, USA. Everyone is permitted to copy and distribute verbatim copies of this license document, but changing it is not allowed.

#### **Preamble**

The licenses for most software are designed to take away your freedom to share and change it. By contrast, the GNU General Public License is intended to guarantee your freedom to share and change free software--to make sure the software is free for all its users. This General Public License applies to most of the Free Software Foundation's software and to any other program whose authors commit to using it. (Some other Free Software Foundation software is covered by the GNU Library General Public License instead.) You can apply it to your programs, too.

When we speak of free software, we are referring to freedom, not price. Our General Public Licenses are designed to make sure that you have the freedom to distribute copies of free software (and charge for this service if you wish), that you receive source code or can get it if you want it, that you can change the software or use pieces of it in new free programs; and that you know you can do these things.

To protect your rights, we need to make restrictions that forbid anyone to deny you these rights or to ask you to surrender the rights. These restrictions translate to certain responsibilities for you if you distribute copies of the software, or if you modify it.

For example, if you distribute copies of such a

program, whether gratis or for a fee, you must give the recipients all the rights that you have. You must make sure that they, too, receive or can get the source code. And you must show them these terms so they know their rights.

We protect your rights with two steps: (1) copyright the software, and (2) offer you this license which gives you legal permission to copy, distribute and/or modify the software.

Also, for each author's protection and ours, we want to make certain that everyone understands that there is no warranty for this free software. If the software is modified by someone else and passed on, we want its recipients to know that what they have is not the original, so that any problems introduced by others will not reflect on the original authors' reputations.

Finally, any free program is threatened constantly by software patents. We wish to avoid the danger that redistributors of a free program will individually obtain patent licenses, in effect making the program proprietary. To prevent this, we have made it clear that any patent must be licensed for everyone's free use or not licensed at all.

The precise terms and conditions for copying, distribution and modification follow.

#### **GNU GENERAL PUBLIC LICENSE TERMS AND CONDITIONS FOR COPYING, DISTRIBUTION AND MODIFICATION**

**0.** This License applies to any program or other work which contains a notice placed by the copyright holder saying it may be distributed under the terms of this General Public License. The "Program", below, refers to any such program or work, and a "work based on the Program" means either the Program or any derivative work under copyright law: that is to say, a work containing the Program or a portion of it, either verbatim or with modifications and/or translated into another language. (Hereinafter, translation is included without limitation in the term "modification".) Each licensee is addressed as "you".

Activities other than copying, distribution and modification are not covered by this License; they are outside its scope. The act of running the Program is not restricted, and the output from the Program is covered only if its contents constitute a work based on the Program (independent of having been made by running the Program). Whether that is true depends on what the Program does.

**1.** You may copy and distribute verbatim copies of the Program's source code as you receive it, in any medium, provided that you conspicuously and appropriately publish on each copy an appropriate copyright notice and disclaimer of warranty; keep intact all the notices that refer to this License and to the absence of any warranty; and give any other recipients of the Program a copy of this License

along with the Program.

You may charge a fee for the physical act of transferring a copy, and you may at your option offer warranty protection in exchange for a fee.

**2.** You may modify your copy or copies of the Program or any portion of it, thus forming a work based on the Program, and copy and distribute such modifications or work under the terms of Section 1 above, provided that you also meet all of these conditions:

**a)** You must cause the modified files to carry prominent notices stating that you changed the files and the date of any change.

**b)** You must cause any work that you distribute or publish, that in whole or in part contains or is derived from the Program or any part thereof, to be licensed as a whole at no charge to all third parties under the terms of this License.

**c)** If the modified program normally reads commands interactively when run, you must cause it, when started running for such interactive use in the most ordinary way, to print or display an announcement including an appropriate copyright notice and a notice that there is no warranty (or else, saying that you provide a warranty) and that users may redistribute the program under these conditions, and telling the user how to view a copy of this License. (Exception: if the Program itself is interactive but does not normally print such an announcement, your work based on the Program is not required to print an announcement.)

These requirements apply to the modified work as a whole. If identifiable sections of that work are not derived from the Program, and can be reasonably considered independent and separate works in themselves, then this License, and its terms, do not apply to those sections when you distribute them as separate works. But when you distribute the same sections as part of a whole which is a work based on the Program, the distribution of the whole must be on the terms of this License, whose permissions for other licensees extend to the entire whole, and thus to each and every part regardless of who wrote it.

Thus, it is not the intent of this section to claim rights or contest your rights to work written entirely by you; rather, the intent is to exercise the right to control the distribution of derivative or collective works based on the Program.

In addition, mere aggregation of another work not based on the Program with the Program (or with a work based on the Program) on a volume of a storage or distribution medium does not bring the other work under the scope of this License.

**3.** You may copy and distribute the Program (or a work based on it, under Section 2) in object code or executable form under the terms of Sections 1 and 2 above provided that you also do one of the following:

**a)** Accompany it with the complete corresponding machine-readable source code, which must be distributed under the terms of Sections 1 and 2 above on a medium customarily used for software interchange; or,

**b)** Accompany it with a written offer, valid for at least three years, to give any third party, for a charge no more than your cost of physically performing source distribution, a complete machine-readable copy of the corresponding source code, to be distributed under the terms of Sections 1 and 2 above on a medium customarily used for software interchange; or,

**c)** Accompany it with the information you received as to the offer to distribute corresponding source code. (This alternative is allowed only for noncommercial distribution and only if you received the program in object code or executable form with such an offer, in accord with Subsection b above.)

The source code for a work means the preferred form of the work for making modifications to it. For an executable work, complete source code means all the source code for all modules it contains, plus any associated interface definition files, plus the scripts used to control compilation and installation of the executable. However, as a special exception, the source code distributed need not include anything that is normally distributed (in either source or binary form) with the major components (compiler, kernel, and so on) of the operating system on which the executable runs, unless that component itself accompanies the executable.

If distribution of executable or object code is made by offering access to copy from a designated place, then offering equivalent access to copy the source code from the same place counts as distribution of the source code, even though third parties are not compelled to copy the source along with the object code.

**4.** You may not copy, modify, sublicense, or distribute the Program except as expressly provided under this License. Any attempt otherwise to copy, modify, sublicense or distribute the Program is void, and will automatically terminate your rights under this License. However, parties who have received copies, or rights, from you under this License will not have their licenses terminated so long as such parties remain in full compliance.

**5.** You are not required to accept this License, since you have not signed it. However, nothing else grants you permission to modify or distribute the Program or its derivative works. These actions are prohibited by law if you do not accept this License. Therefore, by modifying or distributing the Program (or any work based on the Program), you indicate your acceptance of this License to do so, and all its terms and conditions for copying, distributing or modifying the Program or works based on it.

**6.** Each time you redistribute the Program (or

any work based on the Program), the recipient automatically receives a license from the original licensor to copy, distribute or modify the Program subject to these terms and conditions. You may not impose any further restrictions on the recipients' exercise of the rights granted herein. You are not responsible for enforcing compliance by third parties to this License.

**7.** If, as a consequence of a court judgment or allegation of patent infringement or for any other reason (not limited to patent issues), conditions are imposed on you (whether by court order, agreement or otherwise) that contradict the conditions of this License, they do not excuse you from the conditions of this License. If you cannot distribute so as to satisfy simultaneously your obligations under this License and any other pertinent obligations, then as a consequence you may not distribute the Program at all. For example, if a patent license would not permit royalty-free redistribution of the Program by all those who receive copies directly or indirectly through you, then the only way you could satisfy both it and this License would be to refrain entirely from distribution of the Program.

If any portion of this section is held invalid or unenforceable under any particular circumstance, the balance of the section is intended to apply and the section as a whole is intended to apply in other circumstances. It is not the purpose of this section to induce you to infringe any patents or other property right claims or to contest validity of any such claims; this section has the sole purpose of protecting the integrity of the free software distribution system, which is implemented by public license practices. Many people have made generous contributions to the wide range of software distributed through that system in reliance on consistent application of that system; it is up to the author/donor to decide if he or she is willing to distribute software through any other system and a licensee cannot impose that choice.

This section is intended to make thoroughly clear what is believed to be a consequence of the rest of this License.

**8.** If the distribution and/or use of the Program is restricted in certain countries either by patents or by copyrighted interfaces, the original copyright holder who places the Program under this License may add an explicit geographical distribution limitation excluding those countries, so that distribution is permitted only in or among countries not thus excluded. In such case, this License incorporates the limitation as if written in the body of this License.

**9.** The Free Software Foundation may publish revised and/or new versions of the General Public License from time to time. Such new versions will be similar in spirit to the present version, but may differ in detail to address new problems or concerns.

Each version is given a distinguishing version number. If the Program specifies a version number

of this License which applies to it and "any later version", you have the option of following the terms and conditions either of that version or of any later version published by the Free Software Foundation. If the Program does not specify a version number of this License, you may choose any version ever published by the Free Software Foundation.

**10.** If you wish to incorporate parts of the Program into other free programs whose distribution conditions are different, write to the author to ask for permission. For software which is copyrighted by the Free Software Foundation, write to the Free Software Foundation; we sometimes make exceptions for this. Our decision will be guided by the two goals of preserving the free status of all derivatives of our free software and of promoting the sharing and reuse of software generally.

#### **NO WARRANTY**

BECAUSE THE PROGRAM IS LICENSED FREE OF CHARGE, THERE IS NO WARRANTY FOR THE PROGRAM, TO THE EXTENT PERMITTED BY APPLICABLE LAW. EXCEPT WHEN OTHERWISE STATED IN WRITING THE COPYRIGHT HOLDERS AND/OR OTHER PARTIES PROVIDE THE PROGRAM "AS IS" WITHOUT WARRANTY OF ANY KIND, EITHER EXPRESSED OR IMPLIED, INCLUDING, BUT NOT LIMITED TO, THE IMPLIED WARRANTIES OF MERCHANTABILITY AND FITNESS FOR A PARTICULAR PURPOSE. THE ENTIRE RISK AS TO THE QUALITY AND PERFORMANCE OF THE PROGRAM IS WITH YOU. SHOULD THE PROGRAM PROVE DEFECTIVE, YOU ASSUME THE COST OF ALL NECESSARY SERVICING, REPAIR OR CORRECTION. IN NO EVENT UNLESS REQUIRED BY APPLICABLE LAW OR AGREED TO IN WRITING WILL ANY COPYRIGHT HOLDER, OR ANY OTHER PARTY WHO MAY MODIFY AND/OR REDISTRIBUTE THE PROGRAM AS PERMITTED ABOVE, BE LIABLE TO YOU FOR DAMAGES, INCLUDING ANY GENERAL, SPECIAL, INCIDENTAL OR CONSEQUENTIAL DAMAGES ARISING OUT OF THE USE OR INABILITY TO USE THE PROGRAM (INCLUDING BUT NOT LIMITED TO LOSS OF DATA OR DATA BEING RENDERED INACCURATE OR LOSSES SUSTAINED BY YOU OR THIRD PARTIES OR A FAILURE OF THE PROGRAM TO OPERATE WITH ANY OTHER PROGRAMS), EVEN IF SUCH HOLDER OR OTHER PARTY HAS BEEN ADVISED OF THE POSSIBILITY OF SUCH DAMAGES.

#### **END OF TERMS AND CONDITIONS**

##### **How to Apply These Terms to Your New Programs**

If you develop a new program, and you want it to be of the greatest possible use to the public, the best way to achieve this is to make it free software which everyone can redistribute and change under these terms.

To do so, attach the following notices to the program. It is safest to attach them to the start of each source file to most effectively convey the exclusion of warranty; and each file should have at least the

“copyright” line and a pointer to where the full notice is found.

<one line to give the program’s name and a brief idea of what it does.> Copyright (C) <year> <name of author>

This program is free software; you can redistribute it and/or modify it under the terms of the GNU General Public License as published by the Free Software Foundation; either version 2 of the License, or (at your option) any later version.

This program is distributed in the hope that it will be useful, but WITHOUT ANY WARRANTY; without even the implied warranty of MERCHANTABILITY or FITNESS FOR A PARTICULAR PURPOSE. See the GNU General Public License for more details.

You should have received a copy of the GNU General Public License along with this program; if not, write to the Free Software Foundation, Inc., 51 Franklin Street, Fifth Floor, Boston, MA 02110-1301, USA. Also add information on how to contact you by electronic and paper mail.

If the program is interactive, make it output a short notice like this when it starts in an interactive mode: Gnomovision version 69, Copyright (C) year name of author Gnomovision comes with ABSOLUTELY NO WARRANTY; for details type ‘show w’.

This is free software, and you are welcome to redistribute it under certain conditions; type ‘show c’ for details.

The hypothetical commands ‘show w’ and ‘show c’ should show the appropriate parts of the General Public License. Of course, the commands you use may be called something other than ‘show w’ and ‘show c’; they could even be mouse-clicks or menu items--whatever suits your program.

You should also get your employer (if you work as a programmer) or your school, if any, to sign a “copyright disclaimer” for the program, if necessary. Here is a sample; alter the names:

Yoyodyne, Inc., hereby disclaims all copyright interest in the program ‘Gnomovision’ (which makes passes at compilers) written by James Hacker.  
<signature of Ty Coon>, 1 April 1989  
Ty Coon, President of Vice

This General Public License does not permit incorporating your program into proprietary programs. If your program is a subroutine library, you may consider it more useful to permit linking proprietary applications with the library. If this is what you want to do, use the GNU Library General Public License instead of this License.

=====

## GNU LESSER GENERAL PUBLIC LICENSE Version 2.1, February 1999

Copyright (C) 1991, 1999 Free Software Foundation, Inc. 51 Franklin Street, Fifth Floor, Boston, MA 02110-1301, USA. Everyone is permitted to copy and distribute verbatim copies of this license document,

but changing it is not allowed.

[This is the first released version of the Lesser GPL. It also counts as the successor of the GNU Library Public License, version 2, hence the version number 2.1.]

### Preamble

The licenses for most software are designed to take away your freedom to share and change it. By contrast, the GNU General Public Licenses are intended to guarantee your freedom to share and change free software-to make sure the software is free for all its users.

This license, the Lesser General Public License, applies to some specially designated software packages-typically libraries--of the Free Software Foundation and other authors who decide to use it. You can use it too, but we suggest you first think carefully about whether this license or the ordinary General Public License is the better strategy to use in any particular case, based on the explanations below.

When we speak of free software, we are referring to freedom of use, not price. Our General Public Licenses are designed to make sure that you have the freedom to distribute copies of free software (and charge for this service if you wish); that you receive source code or can get it if you want it; that you can change the software and use pieces of it in new free programs; and that you are informed that you can do these things.

To protect your rights, we need to make restrictions that forbid distributors to deny you these rights or to ask you to surrender these rights. These restrictions translate to certain responsibilities for you if you distribute copies of the library or if you modify it.

For example, if you distribute copies of the library, whether gratis or for a fee, you must give the recipients all the rights that we gave you. You must make sure that they, too, receive or can get the source code. If you link other code with the library, you must provide complete object files to the recipients, so that they can relink them with the library after making changes to the library and recompiling it. And you must show them these terms so they know their rights.

We protect your rights with a two-step method: (1) we copyright the library, and (2) we offer you this license, which gives you legal permission to copy, distribute and/or modify the library.

To protect each distributor, we want to make it very clear that there is no warranty for the free library. Also, if the library is modified by someone else and passed on, the recipients should know that what they have is not the original version, so that the original author’s reputation will not be affected by problems that might be introduced by others.

Finally, software patents pose a constant threat to the existence of any free program. We wish to make sure that a company cannot effectively restrict the users of

a free program by obtaining a restrictive license from a patent holder. Therefore, we insist that any patent license obtained for a version of the library must be consistent with the full freedom of use specified in this license.

Most GNU software, including some libraries, is covered by the ordinary GNU General Public License. This license, the GNU Lesser General Public License, applies to certain designated libraries, and is quite different from the ordinary General Public License. We use this license for certain libraries in order to permit linking those libraries into non-free programs.

When a program is linked with a library, whether statically or using a shared library, the combination of the two is legally speaking a combined work, a derivative of the original library. The ordinary General Public License therefore permits such linking only if the entire combination fits its criteria of freedom. The Lesser General Public License permits more lax criteria for linking other code with the library.

We call this license the “Lesser” General Public License because it does Less to protect the user’s freedom than the ordinary General Public License. It also provides other free software developers Less of an advantage over competing non-free programs. These disadvantages are the reason we use the ordinary General Public License for many libraries. However, the Lesser license provides advantages in certain special circumstances.

For example, on rare occasions, there may be a special need to encourage the widest possible use of a certain library, so that it becomes a de-facto standard. To achieve this, non-free programs must be allowed to use the library. A more frequent case is that a free library does the same job as widely used non-free libraries. In this case, there is little to gain by limiting the free library to free software only, so we use the Lesser General Public License.

In other cases, permission to use a particular library in non-free programs enables a greater number of people to use a large body of free software. For example, permission to use the GNU C Library in non-free programs enables many more people to use the whole GNU operating system, as well as its variant, the GNU/Linux operating system.

Although the Lesser General Public License is Less protective of the users’ freedom, it does ensure that the user of a program that is linked with the Library has the freedom and the wherewithal to run that program using a modified version of the Library.

The precise terms and conditions for copying, distribution and modification follow. Pay close attention to the difference between a “work based on the library” and a “work that uses the library”. The former contains code derived from the library, whereas the latter must be combined with the library in order to run.

## GNU LESSER GENERAL PUBLIC LICENSE TERMS AND CONDITIONS FOR COPYING, DISTRIBUTION AND MODIFICATION

0. This License Agreement applies to any software library or other program which contains a notice placed by the copyright holder or other authorized party saying it may be distributed under the terms of this Lesser General Public License (also called “this License”). Each licensee is addressed as “you”.

A “library” means a collection of software functions and/or data prepared so as to be conveniently linked with application programs (which use some of those functions and data) to form executables.

The “Library”, below, refers to any such software library or work which has been distributed under these terms. A “work based on the Library” means either the Library or any derivative work under copyright law: that is to say, a work containing the Library or a portion of it, either verbatim or with modifications and/or translated straightforwardly into another language. (Hereinafter, translation is included without limitation in the term “modification”.)

“Source code” for a work means the preferred form of the work for making modifications to it. For a library, complete source code means all the source code for all modules it contains, plus any associated interface definition files, plus the scripts used to control compilation and installation of the library.

Activities other than copying, distribution and modification are not covered by this License; they are outside its scope. The act of running a program using the Library is not restricted, and output from such a program is covered only if its contents constitute a work based on the Library (independent of the use of the Library in a tool for writing it). Whether that is true depends on what the Library does and what the program that uses the Library does.

1. You may copy and distribute verbatim copies of the Library’s complete source code as you receive it, in any medium, provided that you conspicuously and appropriately publish on each copy an appropriate copyright notice and disclaimer of warranty; keep intact all the notices that refer to this License and to the absence of any warranty; and distribute a copy of this License along with the Library.

You may charge a fee for the physical act of transferring a copy, and you may at your option offer warranty protection in exchange for a fee.

2. You may modify your copy or copies of the Library or any portion of it, thus forming a work based on the Library, and copy and distribute such modifications or work under the terms of Section 1 above, provided that you also meet all of these conditions:

a) The modified work must itself be a software library.

b) You must cause the files modified to carry prominent notices stating that you changed the files and the date of any change.

**c)** You must cause the whole of the work to be licensed at no charge to all third parties under the terms of this License.

**d)** If a facility in the modified Library refers to a function or a table of data to be supplied by an application program that uses the facility, other than as an argument passed when the facility is invoked, then you must make a good faith effort to ensure that, in the event an application does not supply such function or table, the facility still operates, and performs whatever part of its purpose remains meaningful.

(For example, a function in a library to compute square roots has a purpose that is entirely well-defined independent of the application. Therefore, Subsection 2d requires that any application-supplied function or table used by this function must be optional: if the application does not supply it, the square root function must still compute square roots.)

These requirements apply to the modified work as a whole. If identifiable sections of that work are not derived from the Library, and can be reasonably considered independent and separate works in themselves, then this License, and its terms, do not apply to those sections when you distribute them as separate works. But when you distribute the same sections as part of a whole which is a work based on the Library, the distribution of the whole must be on the terms of this License, whose permissions for other licensees extend to the entire whole, and thus to each and every part regardless of who wrote it.

Thus, it is not the intent of this section to claim rights or contest your rights to work written entirely by you; rather, the intent is to exercise the right to control the distribution of derivative or collective works based on the Library.

In addition, mere aggregation of another work not based on the Library with the Library (or with a work based on the Library) on a volume of a storage or distribution medium does not bring the other work under the scope of this License.

**3.** You may opt to apply the terms of the ordinary GNU General Public License instead of this License to a given copy of the Library. To do this, you must alter all the notices that refer to this License, so that they refer to the ordinary GNU General Public License, version 2, instead of to this License. (If a newer version than version 2 of the ordinary GNU General Public License has appeared, then you can specify that version instead if you wish.) Do not make any other change in these notices.

Once this change is made in a given copy, it is irreversible for that copy, so the ordinary GNU General Public License applies to all subsequent copies and derivative works made from that copy. This option is useful when you wish to copy part of the code of the Library into a program that is not a library.

**4.** You may copy and distribute the Library (or a portion or derivative of it, under Section 2) in object code or executable form under the terms of Sections 1 and 2 above provided that you accompany it with the complete corresponding machine-readable source code, which must be distributed under the terms of Sections 1 and 2 above on a medium customarily used for software interchange.

If distribution of object code is made by offering access to copy from a designated place, then offering equivalent access to copy the source code from the same place satisfies the requirement to distribute the source code, even though third parties are not compelled to copy the source along with the object code.

**5.** A program that contains no derivative of any portion of the Library, but is designed to work with the Library by being compiled or linked with it, is called a “work that uses the Library”. Such a work, in isolation, is not a derivative work of the Library, and therefore falls outside the scope of this License.

However, linking a “work that uses the Library” with the Library creates an executable that is a derivative of the Library (because it contains portions of the Library), rather than a “work that uses the library”. The executable is therefore covered by this License. Section 6 states terms for distribution of such executables.

When a “work that uses the Library” uses material from a header file that is part of the Library, the object code for the work may be a derivative work of the Library even though the source code is not. Whether this is true is especially significant if the work can be linked without the Library, or if the work is itself a library. The threshold for this to be true is not precisely defined by law.

If such an object file uses only numerical parameters, data structure layouts and accessors, and small macros and small inline functions (ten lines or less in length), then the use of the object file is unrestricted, regardless of whether it is legally a derivative work. (Executables containing this object code plus portions of the Library will still fall under Section 6.)

Otherwise, if the work is a derivative of the Library, you may distribute the object code for the work under the terms of Section 6. Any executables containing that work also fall under Section 6, whether or not they are linked directly with the Library itself.

**6.** As an exception to the Sections above, you may also combine or link a “work that uses the Library” with the Library to produce a work containing portions of the Library, and distribute that work under terms of your choice, provided that the terms permit modification of the work for the customer's own use and reverse engineering for debugging such modifications.

You must give prominent notice with each copy of the work that the Library is used in it and that the

Library and its use are covered by this License. You must supply a copy of this License. If the work during execution displays copyright notices, you must include the copyright notice for the Library among them, as well as a reference directing the user to the copy of this License. Also, you must do one of these things:

**a)** Accompany the work with the complete corresponding machine-readable source code for the Library including whatever changes were used in the work (which must be distributed under Sections 1 and 2 above); and, if the work is an executable linked with the Library, with the complete machine-readable “work that uses the Library”, as object code and/or source code, so that the user can modify the Library and then relink to produce a modified executable containing the modified Library. (It is understood that the user who changes the contents of definitions files in the Library will not necessarily be able to recompile the application to use the modified definitions.)

**b)** Use a suitable shared library mechanism for linking with the Library. A suitable mechanism is one that (1) uses at run time a copy of the library already present on the user's computer system, rather than copying library functions into the executable, and (2) will operate properly with a modified version of the library, if the user installs one, as long as the modified version is interface-compatible with the version that the work was made with.

**c)** Accompany the work with a written offer, valid for at least three years, to give the same user the materials specified in Subsection 6a, above, for a charge no more than the cost of performing this distribution.

**d)** If distribution of the work is made by offering access to copy from a designated place, offer equivalent access to copy the above specified materials from the same place.

**e)** Verify that the user has already received a copy of these materials or that you have already sent this user a copy.

For an executable, the required form of the “work that uses the Library” must include any data and utility programs needed for reproducing the executable from it. However, as a special exception, the materials to be distributed need not include anything that is normally distributed (in either source or binary form) with the major components (compiler, kernel, and so on) of the operating system on which the executable runs, unless that component itself accompanies the executable.

It may happen that this requirement contradicts the license restrictions of other proprietary libraries that do not normally accompany the operating system. Such a contradiction means you cannot use both them and the Library together in an executable that you distribute.

**7.** You may place library facilities that are a work based on the Library side-by-side in a single library together with other library facilities not covered by this License, and distribute such a combined library, provided that the separate distribution of the work based on the Library and of the other library facilities is otherwise permitted, and provided that you do these two things:

**a)** Accompany the combined library with a copy of the same work based on the Library, uncombined with any other library facilities. This must be distributed under the terms of the Sections above.

**b)** Give prominent notice with the combined library of the fact that part of it is a work based on the Library, and explaining where to find the accompanying uncombined form of the same work.

**8.** You may not copy, modify, sublicense, link with, or distribute the Library except as expressly provided under this License. Any attempt otherwise to copy, modify, sublicense, link with, or distribute the Library is void, and will automatically terminate your rights under this License. However, parties who have received copies, or rights, from you under this License will not have their licenses terminated so long as such parties remain in full compliance.

**9.** You are not required to accept this License, since you have not signed it. However, nothing else grants you permission to modify or distribute the Library or its derivative works. These actions are prohibited by law if you do not accept this License. Therefore, by modifying or distributing the Library (or any work based on the Library), you indicate your acceptance of this License to do so, and all its terms and conditions for copying, distributing or modifying the Library or works based on it.

**10.** Each time you redistribute the Library (or any work based on the Library), the recipient automatically receives a license from the original licensor to copy, distribute, link with or modify the Library subject to these terms and conditions. You may not impose any further restrictions on the recipients' exercise of the rights granted herein. You are not responsible for enforcing compliance by third parties with this License.

**11.** If, as a consequence of a court judgment or allegation of patent infringement or for any other reason (not limited to patent issues), conditions are imposed on you (whether by court order, agreement or otherwise) that contradict the conditions of this License, they do not excuse you from the conditions of this License. If you cannot distribute so as to satisfy simultaneously your obligations under this License and any other pertinent obligations, then as a consequence you may not distribute the Library at all. For example, if a patent license would not permit royalty-free redistribution of the Library by all those who receive copies directly or indirectly through you, then the only way you could satisfy both it and this License would be to refrain entirely from distribution

of the Library.

If any portion of this section is held invalid or unenforceable under any particular circumstance, the balance of the section is intended to apply, and the section as a whole is intended to apply in other circumstances.

It is not the purpose of this section to induce you to infringe any patents or other property right claims or to contest validity of any such claims; this section has the sole purpose of protecting the integrity of the free software distribution system which is implemented by public license practices. Many people have made generous contributions to the wide range of software distributed through that system in reliance on consistent application of that system; it is up to the author/donor to decide if he or she is willing to distribute software through any other system and a licensee cannot impose that choice.

This section is intended to make thoroughly clear what is believed to be a consequence of the rest of this License.

**12.** If the distribution and/or use of the Library is restricted in certain countries either by patents or by copyrighted interfaces, the original copyright holder who places the Library under this License may add an explicit geographical distribution limitation excluding those countries, so that distribution is permitted only in or among countries not thus excluded. In such case, this License incorporates the limitation as if written in the body of this License.

**13.** The Free Software Foundation may publish revised and/or new versions of the Lesser General Public License from time to time. Such new versions will be similar in spirit to the present version, but may differ in detail to address new problems or concerns.

Each version is given a distinguishing version number. If the Library specifies a version number of this License which applies to it and "any later version", you have the option of following the terms and conditions either of that version or of any later version published by the Free Software Foundation. If the Library does not specify a license version number, you may choose any version ever published by the Free Software Foundation.

**14.** If you wish to incorporate parts of the Library into other free programs whose distribution conditions are incompatible with these, write to the author to ask for permission. For software which is copyrighted by the Free Software Foundation, write to the Free Software Foundation; we sometimes make exceptions for this. Our decision will be guided by the two goals of preserving the free status of all derivatives of our free software and of promoting the sharing and reuse of software generally.

#### **NO WARRANTY**

**15.** BECAUSE THE LIBRARY IS LICENSED FREE OF CHARGE, THERE IS NO WARRANTY FOR

THE LIBRARY, TO THE EXTENT PERMITTED BY APPLICABLE LAW. EXCEPT WHEN OTHERWISE STATED IN WRITING THE COPYRIGHT HOLDERS AND/OR OTHER PARTIES PROVIDE THE LIBRARY "AS IS" WITHOUT WARRANTY OF ANY KIND, EITHER EXPRESSED OR IMPLIED, INCLUDING, BUT NOT LIMITED TO, THE IMPLIED WARRANTIES OF MERCHANTABILITY AND FITNESS FOR A PARTICULAR PURPOSE. THE ENTIRE RISK AS TO THE QUALITY AND PERFORMANCE OF THE LIBRARY IS WITH YOU. SHOULD THE LIBRARY PROVE DEFECTIVE, YOU ASSUME THE COST OF ALL NECESSARY SERVICING, REPAIR OR CORRECTION.

**16.** IN NO EVENT UNLESS REQUIRED BY APPLICABLE LAW OR AGREED TO IN WRITING WILL ANY COPYRIGHT HOLDER, OR ANY OTHER PARTY WHO MAY MODIFY AND/OR REDISTRIBUTE THE LIBRARY AS PERMITTED ABOVE, BE LIABLE TO YOU FOR DAMAGES, INCLUDING ANY GENERAL, SPECIAL, INCIDENTAL OR CONSEQUENTIAL DAMAGES ARISING OUT OF THE USE OR INABILITY TO USE THE LIBRARY (INCLUDING BUT NOT LIMITED TO LOSS OF DATA OR DATA BEING RENDERED INACCURATE OR LOSSES SUSTAINED BY YOU OR THIRD PARTIES OR A FAILURE OF THE LIBRARY TO OPERATE WITH ANY OTHER SOFTWARE), EVEN IF SUCH HOLDER OR OTHER PARTY HAS BEEN ADVISED OF THE POSSIBILITY OF SUCH DAMAGES.

#### **END OF TERMS AND CONDITIONS**

##### **How to Apply These Terms to Your New Libraries**

If you develop a new library, and you want it to be of the greatest possible use to the public, we recommend making it free software that everyone can redistribute and change. You can do so by permitting redistribution under these terms (or, alternatively, under the terms of the ordinary General Public License).

To apply these terms, attach the following notices to the library. It is safest to attach them to the start of each source file to most effectively convey the exclusion of warranty; and each file should have at least the "copyright" line and a pointer to where the full notice is found.

<one line to give the library's name and a brief idea of what it does.>

Copyright (C) <year> <name of author>

This library is free software; you can redistribute it and/or modify it under the terms of the GNU Lesser General Public license as published by the Free Software Foundation; either version 2.1 of the License, or (at your option) any later version.

This library is distributed in the hope that it will be useful, but WITHOUT ANY WARRANTY; without even the implied warranty of MERCHANTABILITY or FITNESS FOR A PARTICULAR PURPOSE. See the GNU Lesser General Public License for more details. You should have received a copy of the GNU Lesser General Public License along with this library; if

not, write to the Free Software Foundation, Inc., 51 Franklin Street, Fifth Floor, Boston, MA 02110-1301, USA.

Also add information on how to contact you by electronic and paper mail.

You should also get your employer (if you work as a programmer) or your school, if any, to sign a "copyright disclaimer" for the library, if necessary. Here is a sample; alter the names:

Yoyodyne, Inc., hereby disclaims all copyright interest in the library 'Frob' (a library for tweaking knobs) written by James Random Hacker.  
<signature of Ty Coon>, 1 April 1990  
Ty Coon, President of Vice

#### **Notification of BSD**

Copyright (c) 1994-2004 The NetBSD Foundation, Inc. All rights reserved.

Redistribution and use in source and binary forms, with or without modification, are permitted provided that the following conditions are met:

1. Redistributions of source code must retain the above copyright notice, this list of conditions and the following disclaimer.
2. Redistributions in binary form must reproduce the above copyright notice, this list of conditions and the following disclaimer in the documentation and/or other materials provided with the distribution.
3. All advertising materials mentioning features or use of this software must display the following acknowledgement:  
This product includes software developed by the NetBSD Foundation, Inc. and its contributors.
4. Neither the name of The NetBSD Foundation nor the names of its contributors may be used to endorse or promote products derived from this software without specific prior written permission.

THIS SOFTWARE IS PROVIDED BY THE REGENTS AND CONTRIBUTORS "AS IS" AND ANY EXPRESS OR IMPLIED WARRANTIES, INCLUDING, BUT NOT LIMITED TO, THE IMPLIED WARRANTIES OF MERCHANTABILITY AND FITNESS FOR A PARTICULAR PURPOSE ARE DISCLAIMED. IN NO EVENT SHALL THE REGENTS OR CONTRIBUTORS BE LIABLE FOR ANY DIRECT, INDIRECT, INCIDENTAL, SPECIAL, EXEMPLARY, OR CONSEQUENTIAL DAMAGES (INCLUDING, BUT NOT LIMITED TO, PROCUREMENT OF SUBSTITUTE GOODS OR SERVICES; LOSS OF USE, DATA, OR PROFITS; OR BUSINESS INTERRUPTION) HOWEVER CAUSED AND ON ANY THEORY OF LIABILITY, WHETHER IN CONTRACT, STRICT LIABILITY, OR TORT (INCLUDING NEGLIGENCE OR OTHERWISE) ARISING IN ANY WAY OUT OF THE USE OF THIS SOFTWARE, EVEN IF ADVISED OF THE POSSIBILITY OF SUCH DAMAGE.

The following notices are required to satisfy the

license terms of the software that we have mentioned in this document:

This product includes software developed by the NetBSD Foundation, Inc. and its contributors. This product includes software developed by the University of California, Berkeley and its contributors. This product includes software developed by John Polstra.

This product includes software developed for the NetBSD Project. See <http://www.NetBSD.org/> for information about NetBSD.

This product includes software developed by Winning Strategies, Inc.

This product includes software developed by Michael Graff.

This product includes software developed by Christos Zoulas.

This product includes software developed by Jonathan Stone for the NetBSD Project.

This product includes software developed by Christopher G. Demetriou for the NetBSD Project.

This product includes software developed by Niels Provos.

This product includes software developed by ToolS GmbH.

This product includes software developed by the University of California, Lawrence Berkeley Laboratory.

This product includes software developed by WIDE Project and its contributors.

#### **INDEPENDENT JPEG GROUP SOFTWARE**

This software is based in part on the work of the Independent JPEG Group.

#### **SOFTWARE DEVELOPED BY THE OPENSLL PROJECT FOR USE IN THE SSL TOOLKIT**

Copyright (c) 1998-2007 The OpenSSL Project. All rights reserved.

Redistribution and use in source and binary forms, with or without modification, are permitted provided that the following conditions are met:

1. Redistributions of source code must retain the above copyright notice, this list of conditions and the following disclaimer.
2. Redistributions in binary form must reproduce the above copyright notice, this list of conditions and the following disclaimer in the documentation and/or other materials provided with the distribution.
3. All advertising materials mentioning features or use of this software must display the following acknowledgement: "This product includes software developed by the OpenSSL Project for use in the OpenSSL Toolkit. (<<http://www.openssl.org/>>)"
4. The names "OpenSSL Toolkit" and "OpenSSL Project" must not be used to endorse or promote products derived from this software without prior

written permission. For written permission, please contact openssl-core@openssl.org.

5. Products derived from this software may not be called "OpenSSL" nor may "OpenSSL" appear in their names without prior written permission of the OpenSSL Project.

6. Redistributions of any form whatsoever must retain the following acknowledgment: "This product includes software developed by the OpenSSL Project for use in the OpenSSL Toolkit (<http://www.openssl.org/>)"

THIS SOFTWARE IS PROVIDED BY THE OpenSSL PROJECT "AS IS" AND ANY EXPRESSED OR IMPLIED WARRANTIES, INCLUDING, BUT NOT LIMITED TO, THE IMPLIED WARRANTIES OF MERCHANTABILITY AND FITNESS FOR A PARTICULAR PURPOSE ARE DISCLAIMED. IN NO EVENT SHALL THE OpenSSL PROJECT OR ITS CONTRIBUTORS BE LIABLE FOR ANY DIRECT, INDIRECT, INCIDENTAL, SPECIAL, EXEMPLARY, OR CONSEQUENTIAL DAMAGES (INCLUDING, BUT NOT LIMITED TO, PROCUREMENT OF SUBSTITUTE GOODS OR SERVICES; LOSS OF USE, DATA, OR PROFITS; OR BUSINESS INTERRUPTION) HOWEVER CAUSED AND ON ANY THEORY OF LIABILITY, WHETHER IN CONTRACT, STRICT LIABILITY, OR TORT (INCLUDING NEGLIGENCE OR OTHERWISE) ARISING IN ANY WAY OUT OF THE USE OF THIS SOFTWARE, EVEN IF ADVISED OF THE POSSIBILITY OF SUCH DAMAGE.

This product includes cryptographic software written by Eric Young (eay@cryptsoft.com). This product includes software written by Tim Hudson (tjh@cryptsoft.com).

Original SSLeay License

Copyright (C) 1995-1998 Eric Young (eay@cryptsoft.com) All rights reserved. This package is an SSL implementation written by Eric Young (eay@cryptsoft.com).

The implementation was written so as to conform with Netscapes SSL.

This library is free for commercial and non-commercial use as long as the following conditions are adhered to. The following conditions apply to all code found in this distribution, be it the RC4, RSA, lhash, DES, etc., code; not just the SSL code. The SSL documentation included with this distribution is covered by the same copyright terms except that the holder is Tim Hudson (tjh@cryptsoft.com).

Copyright remains Eric Young's, and as such any Copyright notices in the code are not to be removed. If this package is used in a product, Eric Young should be given attribution as the author of the parts of the library used. This can be in the form of a textual message at program startup or in documentation (online or textual) provided with the package.

Redistribution and use in source and binary forms, with or without modification, are permitted provided that the following conditions are met:

1. Redistributions of source code must retain the copyright notice, this list of conditions and the following disclaimer.
2. Redistributions in binary form must reproduce the above copyright notice, this list of conditions and the following disclaimer in the documentation and/or other materials provided with the distribution.
3. All advertising materials mentioning features or use of this software must display the following acknowledgement: "This product includes cryptographic software written by Eric Young (eay@cryptsoft.com)". The word 'cryptographic' can be left out if the routines from the library being used are not cryptographic related:-).
4. If you include any Windows specific code (or a derivative thereof) from the apps directory (application code) you must include an acknowledgement: "This product includes software written by Tim Hudson (tjh@cryptsoft.com)".

THIS SOFTWARE IS PROVIDED BY ERIC YOUNG "AS IS" AND ANY EXPRESS OR IMPLIED WARRANTIES, INCLUDING, BUT NOT LIMITED TO, THE IMPLIED WARRANTIES OF MERCHANTABILITY AND FITNESS FOR A PARTICULAR PURPOSE ARE DISCLAIMED. IN NO EVENT SHALL THE AUTHOR OR CONTRIBUTORS BE LIABLE FOR ANY DIRECT, INDIRECT, INCIDENTAL, SPECIAL, EXEMPLARY, OR CONSEQUENTIAL DAMAGES (INCLUDING, BUT NOT LIMITED TO, PROCUREMENT OF SUBSTITUTE GOODS OR SERVICES; LOSS OF USE, DATA, OR PROFITS; OR BUSINESS INTERRUPTION) HOWEVER CAUSED AND ON ANY THEORY OF LIABILITY, WHETHER IN CONTRACT, STRICT LIABILITY, OR TORT (INCLUDING NEGLIGENCE OR OTHERWISE) ARISING IN ANY WAY OUT OF THE USE OF THIS SOFTWARE, EVEN IF ADVISED OF THE POSSIBILITY OF SUCH DAMAGE.

The license and distribution terms for any publicly available version or derivative of this code cannot be changed. i.e. this code cannot simply be copied and put under another distribution license [including the GNU Public License.]

#### FREETYPE2 SOFTWARE

The software is based in part of the work of the FreeType Team.

#### EXPAT SOFTWARE

Copyright (c) 1998, 1999, 2000 Thai Open Source Software Center Ltd and Clark Cooper  
Copyright (c) 2001, 2002, 2003, 2004, 2005, 2006 Expat maintainers.  
Permission is hereby granted, free of charge, to any person obtaining a copy of this software and

associated documentation files (the "Software"), to deal in the Software without restriction, including without limitation the rights to use, copy, modify, merge, publish, distribute, sublicense, and/or sell copies of the Software, and to permit persons to whom the Software is furnished to do so, subject to the following conditions:

The above copyright notice and this permission notice shall be included in all copies or substantial portions of the Software.

THE SOFTWARE IS PROVIDED "AS IS", WITHOUT WARRANTY OF ANY KIND, EXPRESS OR IMPLIED, INCLUDING BUT NOT LIMITED TO THE WARRANTIES OF MERCHANTABILITY, FITNESS FOR A PARTICULAR PURPOSE AND NONINFRINGEMENT. IN NO EVENT SHALL THE AUTHORS OR COPYRIGHT HOLDERS BE LIABLE FOR ANY CLAIM, DAMAGES OR OTHER LIABILITY, WHETHER IN AN ACTION OF CONTRACT, TORT OR OTHERWISE, ARISING FROM, OUT OF OR IN CONNECTION WITH THE SOFTWARE OR THE USE OR OTHER DEALINGS IN THE SOFTWARE.

#### CURL SOFTWARE

COPYRIGHT AND PERMISSION NOTICE. Copyright (c) 1996 - 2009, Daniel Stenberg, <daniel@haxx.se>. All rights reserved.

Permission to use, copy, modify, and distribute this software for any purpose with or without fee is hereby granted, provided that the above copyright notice and this permission notice appear in all copies. THE SOFTWARE IS PROVIDED "AS IS", WITHOUT WARRANTY OF ANY KIND, EXPRESS OR IMPLIED, INCLUDING BUT NOT LIMITED TO THE WARRANTIES OF MERCHANTABILITY, FITNESS FOR A PARTICULAR PURPOSE AND NONINFRINGEMENT OF THIRD PARTY RIGHTS. IN NO EVENT SHALL THE AUTHORS OR COPYRIGHT HOLDERS BE LIABLE FOR ANY CLAIM, DAMAGES OR OTHER LIABILITY, WHETHER IN AN ACTION OF CONTRACT, TORT OR OTHERWISE, ARISING FROM, OUT OF OR IN CONNECTION WITH THE SOFTWARE OR THE USE OR OTHER DEALINGS IN THE SOFTWARE. Except as contained in this notice, the name of a copyright holder shall not be used in advertising or otherwise to promote the sale, use or other dealings in this Software without prior written authorization of the copyright holder.

#### LIBPIXMAN

libpixregion

Copyright 1987, 1998 The Open Group.

Permission to use, copy, modify, distribute, and sell this software and its documentation for any purpose is hereby granted without fee, provided that the above copyright notice appear in all copies and that both that copyright notice and this permission notice appear in supporting documentation. The above

copyright notice and this permission notice shall be included in all copies or substantial portions of the Software. THE SOFTWARE IS PROVIDED "AS IS", WITHOUT WARRANTY OF ANY KIND, EXPRESS OR IMPLIED, INCLUDING BUT NOT LIMITED TO THE WARRANTIES OF MERCHANTABILITY, FITNESS FOR A PARTICULAR PURPOSE AND NONINFRINGEMENT. IN NO EVENT SHALL THE OPEN GROUP BE LIABLE FOR ANY CLAIM, DAMAGES OR OTHER LIABILITY, WHETHER IN AN ACTION OF CONTRACT, TORT OR OTHERWISE, ARISING FROM, OUT OF OR IN CONNECTION WITH THE SOFTWARE OR THE USE OR OTHER DEALINGS IN THE SOFTWARE. Except as contained in this notice, the name of The Open Group shall not be used in advertising or otherwise to promote the sale, use or other dealings in this Software without prior written authorization from The Open Group.

Copyright 1987 by Digital Equipment Corporation, Maynard, Massachusetts. All Rights Reserved.

Permission to use, copy, modify, and distribute this software and its documentation for any purpose and without fee is hereby granted, provided that the above copyright notice appear in all copies and that both that copyright notice and this permission notice appear in supporting documentation, and that the name of Digital not be used in advertising or publicity pertaining to distribution of the software without specific, written prior permission. DIGITAL DISCLAIMS ALL WARRANTIES WITH REGARD TO THIS SOFTWARE, INCLUDING ALL IMPLIED WARRANTIES OF MERCHANTABILITY AND FITNESS, IN NO EVENT SHALL DIGITAL BE LIABLE FOR ANY SPECIAL, INDIRECT OR CONSEQUENTIAL DAMAGES OR ANY DAMAGES WHATSOEVER RESULTING FROM LOSS OF USE, DATA OR PROFITS, WHETHER IN AN ACTION OF CONTRACT, NEGLIGENCE OR OTHER TORTIOUS ACTION, ARISING OUT OF OR IN CONNECTION WITH THE USE OR PERFORMANCE OF THIS SOFTWARE.

libic

Copyright © 2001 Keith Packard.

Permission to use, copy, modify, distribute, and sell this software and its documentation for any purpose is hereby granted without fee, provided that the above copyright notice appear in all copies and that both that copyright notice and this permission notice appear in supporting documentation, and that the name of Keith Packard not be used in advertising or publicity pertaining to distribution of the software without specific, written prior permission. Keith Packard makes no representations about the suitability of this software for any purpose. It is provided "as is" without express or implied warranty. KEITH PACKARD DISCLAIMS ALL WARRANTIES WITH REGARD TO THIS SOFTWARE, INCLUDING ALL IMPLIED WARRANTIES OF MERCHANTABILITY AND FITNESS, IN NO EVENT SHALL KEITH PACKARD BE LIABLE FOR ANY SPECIAL, INDIRECT

OR CONSEQUENTIAL DAMAGES OR ANY DAMAGES WHATSOEVER RESULTING FROM LOSS OF USE, DATA OR PROFITS, WHETHER IN AN ACTION OF CONTRACT, NEGLIGENCE OR OTHER TORTIOUS ACTION, ARISING OUT OF OR IN CONNECTION WITH THE USE OR PERFORMANCE OF THIS SOFTWARE.

slim

slim is Copyright © 2003 Richard Henderson

Permission to use, copy, modify, distribute, and sell this software and its documentation for any purpose is hereby granted without fee, provided that the above copyright notice appear in all copies and that both that copyright notice and this permission notice appear in supporting documentation, and that the name of Richard Henderson not be used in advertising or publicity pertaining to distribution of the software without specific, written prior permission. Richard Henderson makes no representations about the suitability of this software for any purpose. It is provided "as is" without express or implied warranty.

RICHARD HENDERSON DISCLAIMS ALL WARRANTIES WITH REGARD TO THIS SOFTWARE, INCLUDING ALL IMPLIED WARRANTIES OF MERCHANTABILITY AND FITNESS, IN NO EVENT SHALL RICHARD HENDERSON BE LIABLE FOR ANY SPECIAL, INDIRECT OR CONSEQUENTIAL DAMAGES OR ANY DAMAGES WHATSOEVER RESULTING FROM LOSS OF USE, DATA OR PROFITS, WHETHER IN AN ACTION OF CONTRACT, NEGLIGENCE OR OTHER TORTIOUS ACTION, ARISING OUT OF OR IN CONNECTION WITH THE USE OR PERFORMANCE OF THIS SOFTWARE.

#### GIFLIB SOFTWARE

The GIFLIB distribution is Copyright (c) 1997 Eric S. Raymond

Permission is hereby granted, free of charge, to any person obtaining a copy of this software and associated documentation files (the "Software"), to deal in the Software without restriction, including without limitation the rights to use, copy, modify, merge, publish, distribute, sublicense, and/or sell copies of the Software, and to permit persons to whom the Software is furnished to do so, subject to the following conditions:

The above copyright notice and this permission notice shall be included in all copies or substantial portions of the Software.

THE SOFTWARE IS PROVIDED "AS IS", WITHOUT WARRANTY OF ANY KIND, EXPRESS OR IMPLIED, INCLUDING BUT NOT LIMITED TO THE WARRANTIES OF MERCHANTABILITY, FITNESS FOR A PARTICULAR PURPOSE AND NONINFRINGEMENT. IN NO EVENT SHALL THE AUTHORS OR COPYRIGHT HOLDERS BE LIABLE FOR ANY CLAIM, DAMAGES OR OTHER LIABILITY, WHETHER IN AN ACTION

OF CONTRACT, TORT OR OTHERWISE, ARISING FROM, OUT OF OR IN CONNECTION WITH THE SOFTWARE OR THE USE OR OTHER DEALINGS IN THE SOFTWARE.

#### 802.11 WLAN DRIVER SOFTWARE

802.11 WLAN driver

Copyright held by  
Sam Leffler, Erno Consulting,  
Atsushi Onoe,  
Atheros Communications, Inc.  
Video54 Technologies, Inc.  
The Regents of the University of California.  
Jouni Malinen <jkmaline@cc.hut.fi>  
Jonathan Stone and Jason R. Thorpe  
Gunter Burchardt, Local-Web AG

Redistribution and use in source and binary forms, with or without modification, are permitted provided that the following conditions are met:

1. Redistributions of source code must retain the above copyright notice, this list of conditions and the following disclaimer.
2. Redistributions in binary form must reproduce the above copyright notice, this list of conditions and the following disclaimer in the documentation and/or other materials provided with the distribution.
3. The name of the author may not be used to endorse or promote products derived from this software without specific prior written permission.

THIS SOFTWARE IS PROVIDED BY copyright holder "AS IS" AND ANY EXPRESS OR IMPLIED WARRANTIES, INCLUDING, BUT NOT LIMITED TO, THE IMPLIED WARRANTIES OF MERCHANTABILITY AND FITNESS FOR A PARTICULAR PURPOSE ARE DISCLAIMED. IN NO EVENT SHALL copyright holder BE LIABLE FOR ANY DIRECT, INDIRECT, INCIDENTAL, SPECIAL, EXEMPLARY, OR CONSEQUENTIAL DAMAGES (INCLUDING, BUT NOT LIMITED TO, PROCUREMENT OF SUBSTITUTE GOODS OR SERVICES; LOSS OF USE, DATA, OR PROFITS; OR BUSINESS INTERRUPTION) HOWEVER CAUSED AND ON ANY THEORY OF LIABILITY, WHETHER IN CONTRACT, STRICT LIABILITY, OR TORT (INCLUDING NEGLIGENCE OR OTHERWISE) ARISING IN ANY WAY OUT OF THE USE OF THIS SOFTWARE, EVEN IF ADVISED OF THE POSSIBILITY OF SUCH DAMAGE.

#### WPA SUPPLICANT SOFTWARE

WPA Supplicant

Copyright (c) 2003-2007, Jouni Malinen <j@w1.fi> and contributors All Rights Reserved.

Redistribution and use in source and binary forms, with or without modification, are permitted provided that the following conditions are met:

1. Redistributions of source code must retain the

above copyright notice, this list of conditions and the following disclaimer.

2. Redistributions in binary form must reproduce the above copyright notice, this list of conditions and the following disclaimer in the documentation and/or other materials provided with the distribution.

3. Neither the name(s) of the above-listed copyright holder(s) nor the names of its contributors may be used to endorse or promote products derived from this software without specific prior written permission.

THIS SOFTWARE IS PROVIDED BY THE COPYRIGHT HOLDERS AND CONTRIBUTORS "AS IS" AND ANY EXPRESS OR IMPLIED WARRANTIES, INCLUDING, BUT NOT LIMITED TO, THE IMPLIED WARRANTIES OF MERCHANTABILITY AND FITNESS FOR A PARTICULAR PURPOSE ARE DISCLAIMED. IN NO EVENT SHALL THE COPYRIGHT OWNER OR CONTRIBUTORS BE LIABLE FOR ANY DIRECT, INDIRECT, INCIDENTAL, SPECIAL, EXEMPLARY, OR CONSEQUENTIAL DAMAGES (INCLUDING, BUT NOT LIMITED TO, PROCUREMENT OF SUBSTITUTE GOODS OR SERVICES; LOSS OF USE, DATA, OR PROFITS; OR BUSINESS INTERRUPTION) HOWEVER CAUSED AND ON ANY THEORY OF LIABILITY, WHETHER IN CONTRACT, STRICT LIABILITY, OR TORT (INCLUDING NEGLIGENCE OR OTHERWISE) ARISING IN ANY WAY OUT OF THE USE OF THIS SOFTWARE, EVEN IF ADVISED OF THE POSSIBILITY OF SUCH DAMAGE.

#### LIBXMLE2 SOFTWARE

Except where otherwise noted in the source code (e.g. the files hash.c, list.c and the trio files, which are covered by a similar licence but with different Copyright notices) all the files are:

Copyright (C) 1998-2003 Daniel Veillard. All Rights Reserved.

Permission is hereby granted, free of charge, to any person obtaining a copy of this software and associated documentation files (the "Software"), to deal in the Software without restriction, including without limitation the rights to use, copy, modify, merge, publish, distribute, sublicense, and/or sell copies of the Software, and to permit persons to whom the Software is furnished to do so, subject to the following conditions:

The above copyright notice and this permission notice shall be included in all copies or substantial portions of the Software.

THE SOFTWARE IS PROVIDED "AS IS", WITHOUT WARRANTY OF ANY KIND, EXPRESS OR IMPLIED, INCLUDING BUT NOT LIMITED TO THE WARRANTIES OF MERCHANTABILITY, FIT-NESS FOR A PARTICULAR PURPOSE AND NONINFRINGEMENT. IN NO EVENT SHALL THE DANIEL VEILLARD BE LIABLE FOR ANY CLAIM, DAMAGES OR OTHER LIABILITY, WHETHER IN AN ACTION OF CONTRACT,

TORT OR OTHERWISE, ARISING FROM, OUT OF OR IN CONNECTION WITH THE SOFTWARE OR THE USE OR OTHER DEALINGS IN THE SOFTWARE.

Except as contained in this notice, the name of Daniel Veillard shall not be used in advertising or otherwise to promote the sale, use or other dealings in this Software without prior written authorization from him.

#### LIBMNG SOFTWARE

Copyright (c) 2000-2007 Gerard Juyn  
[You may insert additional notices after this sentence if you modify this source]

For the purposes of this copyright and license, "Contributing Authors" is defined as the following set of individuals:

Gerard Juyn- gjuyn :at: users.sourceforge.net  
Glenn Randers-Pehrson-glennrp :at: users.sourceforge.net  
Raphael Assenat- raph :at: raphnet.net  
ohn Stiles

The MNG Library is supplied "AS IS". The Contributing Authors disclaim all warranties, expressed or implied, including, without limitation, the warranties of merchantability and of fitness for any purpose. The Contributing Authors assume no liability for direct, indirect, incidental, special, exemplary, or consequential damages, which may result from the use of the MNG Library, even if advised of the possibility of such damage.

Permission is hereby granted to use, copy, modify, and distribute this source code, or portions hereof, for any purpose, without fee, subject to the following restrictions:

1. The origin of this source code must not be misrepresented; you must not claim that you wrote the original software.
  2. Altered versions must be plainly marked as such and must not be misrepresented as being the original source.
  3. This Copyright notice may not be removed or altered from any source or altered source distribution.
- The Contributing Authors specifically permit, without fee, and encourage the use of this source code as a component to supporting the MNG and JNG file format in commercial products. If you use this source code in a product, acknowledgment would be highly appreciated.

Parts of this software have been adapted from the libpng package. Although this library supports all features from the PNG specification (as MNG descends from it) it does not require the libpng package. It does require the zlib library and optionally the IJG jpeg library, and/or the "little-cms" library by Marti Maria (depending on the inclusion of support for JNG and Full-Color-Management respectively).

This library's function is primarily to read and display MNG animations. It is not meant as a full-featured image-editing component! It does however offer creation and editing functionality at the chunk level. (future modifications may include some more support for creation and or editing)

#### FONTCONFIG SOFTWARE

fontconfig/fontconfig/fontconfig.h

Copyright (c) 2001 Keith Packard

Permission to use, copy, modify, distribute, and sell this software and its documentation for any purpose is hereby granted without fee, provided that the above copyright notice appear in all copies and that both that copyright notice and this permission notice appear in supporting documentation, and that the name of Keith Packard not be used in advertising or publicity pertaining to distribution of the software without specific, written prior permission. Keith Packard makes no representations about the suitability of this software for any purpose. It is provided "as is" without express or implied warranty.

THE AUTHOR(S) DISCLAIMS ALL WARRANTIES WITH REGARD TO THIS SOFTWARE, INCLUDING ALL IMPLIED WARRANTIES OF MERCHANTABILITY AND FITNESS, IN NO EVENT SHALL THE AUTHOR(S) BE LIABLE FOR ANY SPECIAL, INDIRECT OR CONSEQUENTIAL DAMAGES OR ANY DAMAGES WHATSOEVER RESULTING FROM LOSS OF USE, DATA OR PROFITS, WHETHER IN AN ACTION OF CONTRACT, NEGLIGENCE OR OTHER TORTIOUS ACTION, ARISING OUT OF OR IN CONNECTION WITH THE USE OR PERFORMANCE OF THIS SOFTWARE.

#### C-ARES SOFTWARE

Copyright 1998 by the Massachusetts Institute of Technology.

Copyright (C) 2007-2008 by Daniel Stenberg

Permission to use, copy, modify, and distribute this software and its documentation for any purpose and without fee is hereby granted, provided that the above copyright notice appear in all copies and that both that copyright notice and this permission notice appear in supporting documentation, and that the name of M.I.T. not be used in advertising or publicity pertaining to distribution of the software without specific, written prior permission.

M.I.T. makes no representations about the suitability of this software for any purpose. It is provided "as is" without express or implied warranty.

#### ICU License - ICU 1.8.1 and later COPYRIGHT AND PERMISSION NOTICE

Copyright (c) 1995-2009 International Business Machines Corporation and others All rights reserved.

Permission is hereby granted, free of charge, to any person obtaining a copy of this software and associated documentation files (the "Software"), to deal in the Software without restriction, including without limitation the rights to use, copy, modify, merge, publish, distribute, and/or sell copies of the Software, and to permit persons to whom the Software is furnished to do so, provided that the above copyright notice(s) and this permission notice appear in all copies of the Software and that both the above copyright notice(s) and this permission notice appear in supporting documentation.

THE SOFTWARE IS PROVIDED "AS IS", WITHOUT WARRANTY OF ANY KIND, EXPRESS OR IMPLIED, INCLUDING BUT NOT LIMITED TO THE WARRANTIES OF MERCHANTABILITY, FITNESS FOR A PARTICULAR PURPOSE AND NONINFRINGEMENT OF THIRD PARTY RIGHTS. IN NO EVENT SHALL THE COPYRIGHT HOLDER OR HOLDERS INCLUDED IN THIS NOTICE BE LIABLE FOR ANY CLAIM, OR ANY SPECIAL INDIRECT OR CONSEQUENTIAL DAMAGES, OR ANY DAMAGES WHATSOEVER RESULTING FROM LOSS OF USE, DATA OR PROFITS, WHETHER IN AN ACTION OF CONTRACT, NEGLIGENCE OR OTHER TORTIOUS ACTION, ARISING OUT OF OR IN CONNECTION WITH THE USE OR PERFORMANCE OF THIS SOFTWARE.

Except as contained in this notice, the name of a copyright holder shall not be used in advertising or otherwise to promote the sale, use or other dealings in this Software without prior written authorization of the copyright holder.

#### FreeBSD SOFTWARE

Copyright (c) 1982, 1986, 1993 The Regents of the University of California. All rights reserved.

Redistribution and use in source and binary forms, with or without modification, are permitted provided that the following conditions are met:

1. Redistributions of source code must retain the above copyright notice, this list of conditions and the following disclaimer.
2. Redistributions in binary form must reproduce the above copyright notice, this list of conditions and the following disclaimer in the documentation and/or other materials provided with the distribution.
3. Neither the name of the University nor the names of its contributors may be used to endorse or promote products derived from this software without specific prior written permission.

THIS SOFTWARE IS PROVIDED BY THE REGENTS AND CONTRIBUTORS "AS IS" AND ANY EXPRESS

OR IMPLIED WARRANTIES, INCLUDING, BUT NOT LIMITED TO, THE IMPLIED WARRANTIES OF MERCHANTABILITY AND FITNESS FOR A PARTICULAR PURPOSE ARE DISCLAIMED. IN NO EVENT SHALL THE REGENTS OR CONTRIBUTORS BE LIABLE FOR ANY DIRECT, INDIRECT, INCIDENTAL, SPECIAL, EXEMPLARY, OR CONSEQUENTIAL DAMAGES (INCLUDING, BUT NOT LIMITED TO, PROCUREMENT OF SUBSTITUTE GOODS OR SERVICES; LOSS OF USE, DATA, OR PROFITS; OR BUSINESS INTERRUPTION) HOWEVER CAUSED AND ON ANY THEORY OF LIABILITY, WHETHER IN CONTRACT, STRICT LIABILITY, OR TORT (INCLUDING NEGLIGENCE OR OTHERWISE) ARISING IN ANY WAY OUT OF THE USE OF THIS SOFTWARE, EVEN IF ADVISED OF THE POSSIBILITY OF SUCH DAMAGE.

#### Notification of MPEG-4 Visual

THIS PRODUCT IS LICENSED UNDER THE MPEG-4 VISUAL PATENT PORTFOLIO LICENSE FOR THE PERSONAL AND NON-COMMERCIAL USE OF A CONSUMER FOR

- (i) ENCODING VIDEO IN COMPLIANCE WITH THE MPEG-4 VISUAL STANDARD ("MPEG-4 VIDEO") AND/OR
- (ii) DECODING MPEG-4 VIDEO THAT WAS ENCODED BY A CONSUMER ENGAGED IN A PERSONAL AND NON-COMMERCIAL ACTIVITY AND/OR WAS OBTAINED FROM A VIDEO PROVIDER LICENSED BY MPEG LA TO PROVIDE MPEG-4 VIDEO.

NO LICENSE IS GRANTED OR SHALL BE IMPLIED FOR ANY OTHER USE. ADDITIONAL INFORMATION INCLUDING THAT RELATING TO PROMOTIONAL, INTERNAL AND COMMERCIAL USES AND LICENSING MAY BE OBTAINED FROM MPEG LA, LLC. SEE [HTTP://WWW.MPEGLA.COM](http://www.mpegla.com)

#### Notification of MPEG-4 AVC

THIS PRODUCT IS LICENSED UNDER THE AVC PATENT PORTFOLIO LICENSE FOR THE PERSONAL AND NON-COMMERCIAL USE OF A CONSUMER TO

- (i) ENCODE VIDEO IN COMPLIANCE WITH THE AVC STANDARD ("AVC VIDEO") AND/OR
- (ii) DECODE AVC VIDEO THAT WAS ENCODED BY A CONSUMER ENGAGED IN A PERSONAL AND

NON-COMMERCIAL ACTIVITY AND/OR WAS OBTAINED FROM A VIDEO PROVIDER LICENSED TO PROVIDE AVC VIDEO. NO LICENSE IS GRANTED OR SHALL BE IMPLIED FOR ANY OTHER USE. ADDITIONAL INFORMATION MAY BE OBTAINED FROM MPEG LA, L.L.C. SEE [HTTP://WWW.MPEGLA.COM](http://www.mpegla.com)

#### Notification of VC-1

THIS PRODUCT IS LICENSED UNDER THE VC-1 PATENT PORTFOLIO LICENSE FOR THE PERSONAL AND NON-COMMERCIAL USE OF A CONSUMER TO

- (i) ENCODE VIDEO IN COMPLIANCE WITH THE VC-1 STANDARD ("VC-1 VIDEO") AND/OR
- (ii) DECODE VC-1 VIDEO THAT WAS ENCODED BY A CONSUMER ENGAGED IN A PERSONAL AND NON-COMMERCIAL ACTIVITY AND/OR WAS OBTAINED FROM A VIDEO PROVIDER LICENSED TO PROVIDE VC-1 VIDEO.

NO LICENSE IS GRANTED OR SHALL BE IMPLIED FOR ANY OTHER USE. ADDITIONAL INFORMATION MAY BE OBTAINED FROM MPEG LA, L.L.C. SEE [HTTP://WWW.MPEGLA.COM](http://www.mpegla.com)

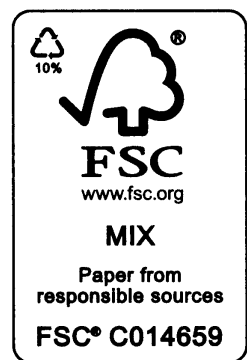

**SONY**

LCD Television 12M

## LIMITED WARRANTY (U.S. ONLY)

SONY ELECTRONICS INC. ("SONY") warrants this product against defects in material or workmanship for the original and any subsequent end user owner(s) ("You" or "Your") for the time periods and as set forth below. Under this Limited Warranty, SONY will, at its option, (i) repair the product using new or refurbished parts or (ii) replace the product with a new or refurbished product. "Refurbished" means a product or part that has been returned to its original specifications. **These are Your exclusive remedies.** SONY does not warrant that the operation of the product will be uninterrupted or error-free.

Term: One (1) year from the original date of purchase of the product (or ninety (90) days from original date of purchase for commercial use). This Limited Warranty is transferable. However, any transfer of this product does not extend the term. **A copy of the dated receipt or bill of sale from the original end user purchase is required to determine coverage. Online auction confirmations are not accepted for warranty verification.**

Product Coverage: Only the hardware components packaged with the Product are covered. Technical assistance for hardware or software usage and any software products are not covered. Any software is provided "AS IS" unless expressly provided for in any enclosed software Limited Warranty. When a product or part is exchanged, the original item becomes SONY's property. Any replacement product provided under this limited warranty may vary in the color and/or cosmetic design from the original product and may not include any original engraving or similar customization.

Instructions: You must contact SONY or an authorized servicer prior to returning any product for warranty service. SONY will not reimburse You for service performed by others. Unless otherwise instructed by SONY or an authorized servicer, You must deliver the product, freight prepaid, in either its original packaging or packaging affording an equal degree of protection to the facility specified by SONY.

For specific instructions on obtaining warranty service for your product,

**Visit SONY's Web Site: [www.sony.com/support](http://www.sony.com/support)  
Or call the Sony Customer Information Service Center  
1-800-222-SONY (7669)  
For an accessory or part not available from Your authorized dealer, call:  
1-800-488-SONY (7669)**

If You purchased an extended service plan, please refer to the service plan for the coverage, duration and terms of service as they are not governed by this Limited Warranty.

Repair/Replacement Warranty: This Limited Warranty shall apply to any repair, replacement part or replacement product for the remainder of the original Limited Warranty period or for ninety (90) days, whichever is longer.

*(See reverse for additional terms and conditions.)*

Printed in U.S.A.

Limitations: This Limited Warranty only covers product issues caused by defects in material or workmanship during ordinary consumer use; it does not cover product issues caused by any other reason, including but not limited to, (i) product issues due to acts of God or nature; (ii) misuse; (iii) accidental damage, including contact with liquid, extreme heat or foreign material; (iv) customer installation, set up adjustments or signal reception issues; (v) limitations of technology; (vi) modification of or to any part of the SONY product, including the antenna; (vii) cosmetic damage; (viii) use or installation inconsistent with the owner's manual and other SONY instruction; (ix) use of parts or peripherals not recommended by SONY; damage caused by servicing not authorized by SONY or third-party calibration; or (x) damage caused by computer or internet viruses, bugs, worms or Trojan Horses. This Limited Warranty does not cover up to .01% pixel outages (small dot picture elements that are dark or incorrectly illuminated). A Display contains hundreds of thousands of individual pixels. Displays typically contain a small number of pixels that do not function normally.

This Limited Warranty does not cover SONY products sold "AS IS", "Open Box", "WITH ALL FAULTS" or similar notations and does not cover consumables (such as fuses or disposable batteries). SONY will not replace missing components from any package purchased "AS IS", "Open Box" or through an online auction. This Limited Warranty is invalid if the factory-applied serial number has been altered or removed from the product. This Limited Warranty is valid only on products purchased and located in the United States (excluding territories) or United States military facilities.

SONY specifically does not represent that it will be able to repair any product under this warranty or make a product exchange without risk to or loss of programs or data.

LIMITATION ON DAMAGES: SONY SHALL NOT BE LIABLE FOR ANY INCIDENTAL OR CONSEQUENTIAL DAMAGES FOR BREACH OF ANY EXPRESS OR IMPLIED WARRANTY ON THIS PRODUCT NOR SHALL RECOVERY OF ANY KIND AGAINST SONY BE GREATER THAN THE PURCHASE PRICE OF THE PRODUCT.

DURATION OF IMPLIED WARRANTIES: EXCEPT TO THE EXTENT PROHIBITED BY APPLICABLE LAW, ANY IMPLIED WARRANTY OF MERCHANTABILITY OR FITNESS FOR A PARTICULAR PURPOSE ON THIS PRODUCT IS LIMITED IN DURATION TO THE DURATION OF THIS WARRANTY. WITH RESPECT TO COMMERCIAL PURCHASERS, ALL IMPLIED WARRANTIES, INCLUDING THE IMPLIED WARRANTIES OF MERCHANTABILITY AND FITNESS FOR A PARTICULAR PURPOSE, ARE EXCLUDED AND DISCLAIMED.

Some states do not allow the exclusion or limitation of incidental or consequential damages, or allow limitations on how long an implied warranty lasts, so the above limitations or exclusions may not apply to You. This Limited Warranty gives You specific legal rights and You may have other rights which vary from state to state.

No Sony reseller, agent or employee is authorized to make any modification, extension or addition to this warranty.