

Quick Setup and Operations



The following list summarizes DCS-100 setup and operations. For error-free installation, always refer to the listed section in the User's Guide.

- Connect Power** — Ensure that power is properly connected to the DCS-100. (Chapter 3, "Power Installation")
- Connect Inputs** — Connect all analog, DVI, and SDI input sources to the DCS-100. (Chapter 3, "Signal Installation")
- Connect Outputs** — Connect the output(s) of the DCS-100 to your projector(s) or other target devices. (Chapter 3, "Signal Installation")
- Power On** — Turn on power to the DCS-100, your projector(s), and to all peripheral equipment. (Chapter 4, "Power-Up Initialization")
- Factory Reset** — When using a DCS-100 for the first time, perform a factory reset. (Chapter 4, "Factory Reset")

- Launch GUI** — (Optional) Connect your laptop to the DCS-100, log onto the DCS-100 using its IP address, and launch the GUI. (Chapter 5, "GUI Operations")
- Set Output Format** — Set the desired output resolution and frame rate. (Chapter 4, "Output Format")
- Enable Test Pattern** — Turn on a test pattern, verify an image, and adjust as required. When complete, turn off the pattern. (Chapter 4, "Test Pattern")
- Save Output Configuration** — After completing all output adjustments, save the output configuration. (Chapter 4, "Save Output Config")
- Select and Adjust Input** — Select an input, and perform the necessary image adjustments. (Chapter 4, "Input Menu")
- Save Input Configuration** — After completing all adjustments for an input, save the input configuration. (Chapter 4, "Save Input Config")
- Repeat for Each Input** — Repeat steps 9 and 10 for each input that you have connected to the DCS-100.
- Adjust Key Source** — As required, select the desired key source and adjust its clip, gain and opacity. (Chapter 4, "Using Keys")
- Adjust System Parameters** — Adjust parameters such as transition time, display brightness, user prefs. (Chapter 4, "Trans Time," "System Menu")
- Save System Configuration** — After completing all system adjustments, save the system configuration. (Chapter 4, "Save System State")
- Enable Remote Control** — (Optional) Connect Ethernet or Serial communications, and issue desired commands. (Appendix B, "Remote Control")
- Ready to Roll** — With all output, input and system configurations saved, press the desired input button, and press **TAKE**.

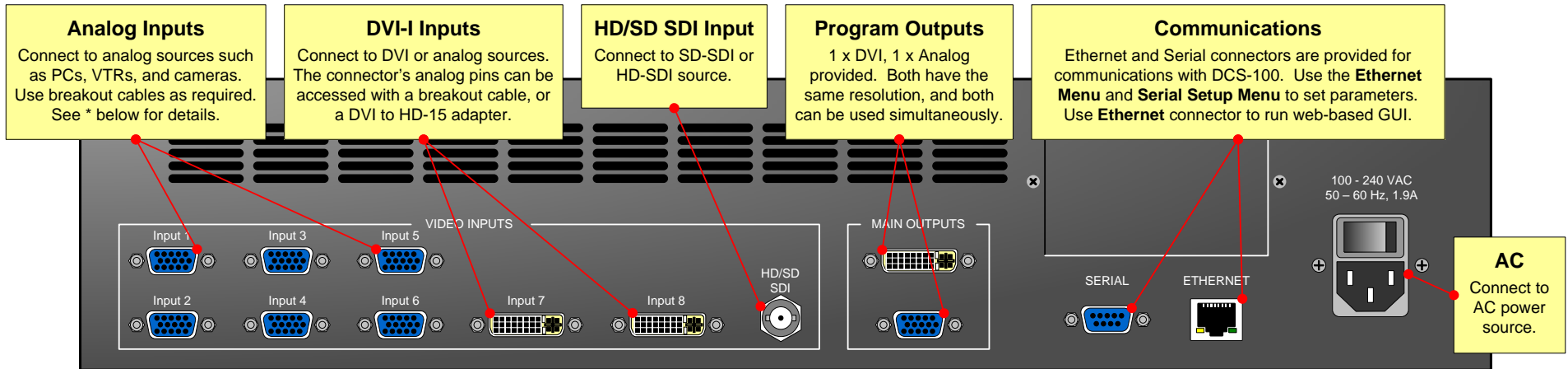

Status Menu

```
PROGRAM:      RGB
             1024x768 @59.94
NEXT:         SDI
             NTSC (480i)
```

← Program Input Type
 ← Program Input Format
 ← Next Input Type
 ← Next Input Format

Sample Status Menu

- Input Type** — Specifies the type of input signal currently on Program.
- Input Format** — Indicates video format on Program. If the input is not valid, "Invalid Signal" is shown.
- Next Input Type** — Indicates next Program input type, plus HDCP status (if applicable).
- Next Input Format** — Indicates next Program input format.

IMPORTANT If "HDCP Violation" appears, an HDCP source is selected, but a non-HDCP compliant display device has been detected. Video output is disabled.

NOTE

- To display the **Setup Menu** from the **Status Menu**, press **SEL**.
- To return to the **Status Menu** from any point in the **Setup Menu**, press **ESC** repeatedly.

Menu Tree — only top level functions are shown

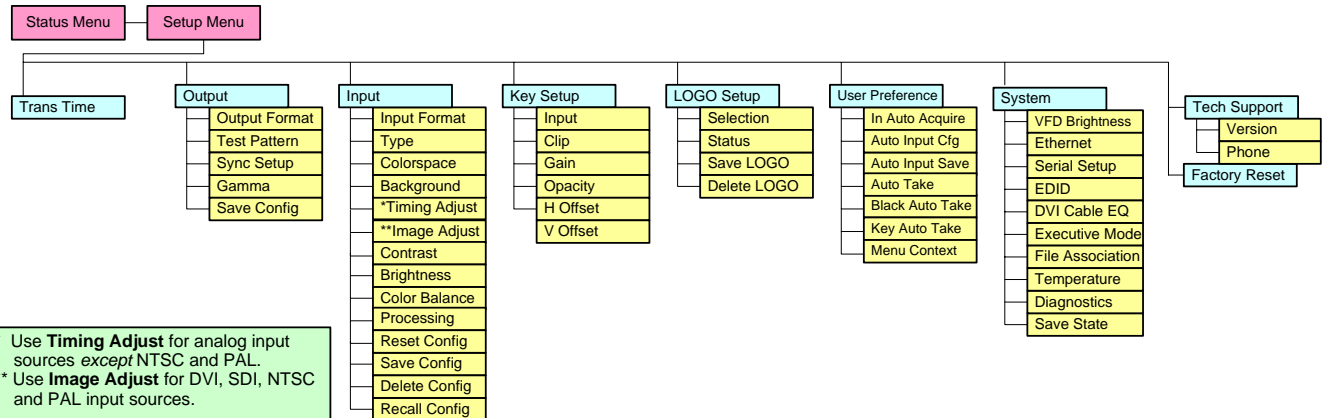

* Breakout Cables for Analog Inputs

Use this table to connect various source formats to the DCS-100, using the system's analog input connectors (**Inputs 1 - 6**).

Breakout Cable Wire Color	Comp Video	S-Video (Y/C)	YUV (YPbPr)	RGB Sync on Green	RGB Comp Sync	RGB Separate H V
R	Red		✓ (Pr)	✓	✓	✓
G	Green	✓ (Lum)	✓ (Lum)	✓	✓	✓
B	Blue	✓ (Chrom)	✓ (Pb)	✓	✓	✓
H Sync					✓	✓
V Sync						✓

For complete details on all installation, setup, and operating procedures, refer to the **DCS-100 User's Guide**.