

THESE DRAWINGS AND SPECIFICATIONS ARE THE PROPERTY OF JBL INCORPORATED. THEY ARE ISSUED IN STRICT CONFIDENCE AND SHALL NOT BE REPRODUCED OR USED AS THE BASIS FOR MANUFACTURE OR APPARATUS WITHOUT WRITTEN PERMISSION.

ALL MATERIAL SPECIFIED ON THIS DRAWING SHALL CONTINUALLY COMPLY WITH THE EFFECTIVE EU RoHS DIRECTIVE, CURRENTLY 2011/65/EU, INCLUDING ALL AMENDMENTS.

REVISIONS				
LTR	DESCRIPTION	DRFT	DATE	APPR
A	INITIAL RELEASE	SCOTT	10/29/2021	
B	UPDATE WEIGHT DATA	SCOTT	12/22/2021	

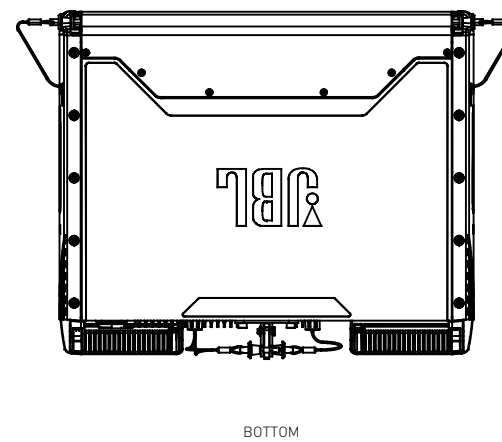
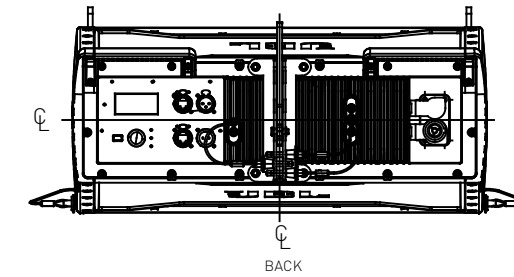
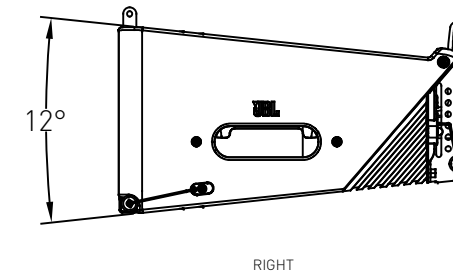
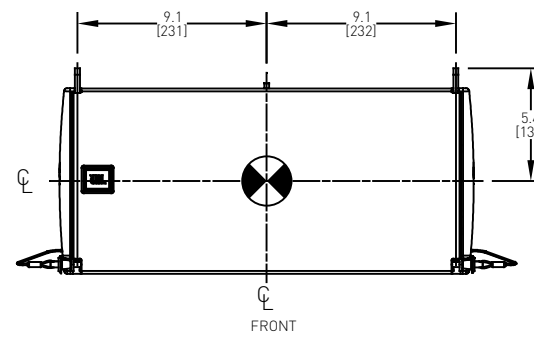
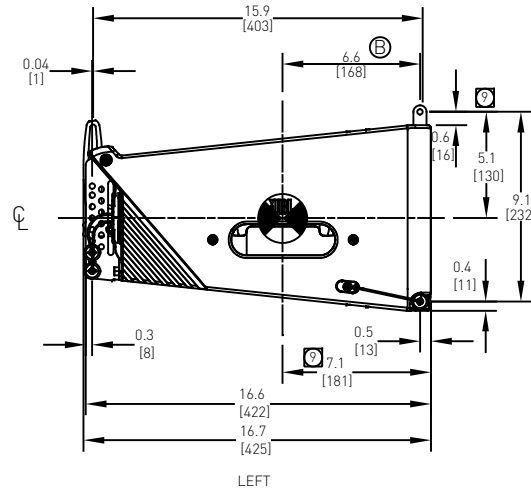
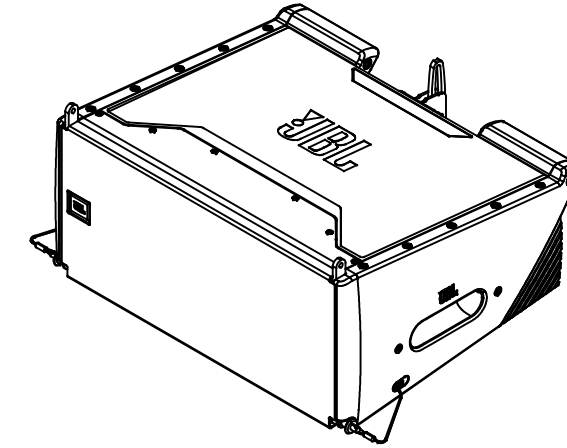
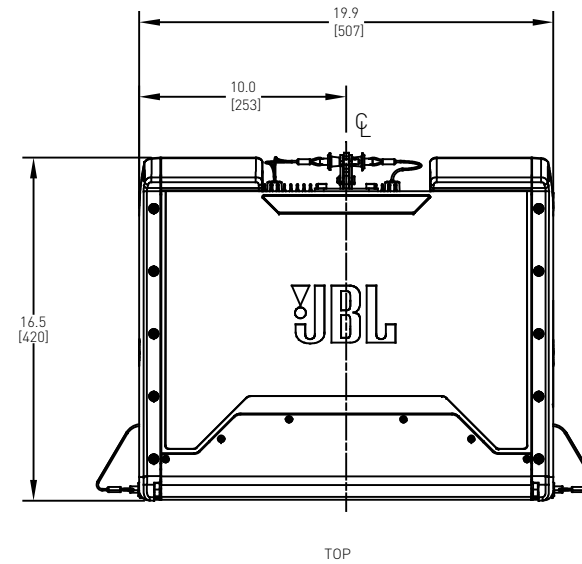

⑨ INDICATED DIMENSIONS ARE TO [CG].

8. SYMBOL INDICATES CENTER OF GRAVITY (CG).

7. THREE-POINT, CAPTIVE SUSPENSION, QUICK RELEASE PINS, STEEL WITH ANTI-CORROSION COATING.

6. COMPONENTS: LF - (2) 2186G, HF - 2432H.

5. GRILLE MATERIAL: 1.5mm (16GAUGE) SPCC POWERCOATED BLACK AND CLOTH BACKING.

4. AUDIO INPUT CONNECTORS: (1) XLR NEUTRIK.  
 AUDIO THROUGH OUT CONNECTORS: (1) XLR NEUTRIK.  
 ETHERNET IN AND THROUGH OUT CONNECTORS: (2) ETHERCON NEUTRIK.  
 POWER IN AND THROUGH OUT CONNECTORS: (1) POWERCON NEUTRIK.

3. WEIGHT: 16.8 KG (37 LBS).

2. FINISH: TEXTURE XH-827.

1. CABINET MATERIAL: POLYPROPYLENE.

NOTES: (UNLESS OTHERWISE SPECIFIED)

**TOLERANCES**

(UNLESS OTHERWISE SPECIFIED)

XX ± .063 INCH

XX ± .125 INCH

ANGULAR TOLERANCE OF 0°±30'

FRACTIONAL DIMENSIONS ± 1/32

\* DIMENSIONS ARE INCHES INCHES [MM]

\* ALL DIMENSIONS ARE FINISHED DIMENSIONS

\* DO NOT SCALE DRAWING

**HARMAN**

JBL Professional  
 8500 Balboa Blvd  
 Northridge, CA 91329  
 USA

TITLE  
**CUSTOMER DRAWING: SRX906LA**

SIZE	DRAWING NO.	REV
<b>A</b>	1000368092	<b>B</b>

SCALE	SHEET	OF
NTS	1	1